

**LTCM Series
Motorized Force Testers**

Operator's Manual



| | Page | | Page |
|---------------------------------------|-------------|--|-------------|
| Introduction..... | 4 | Using Mechanical Load Limits | 22 |
| Force Gauges..... | 4 | Setting High Limit | 22 |
| Getting Started..... | 5 | Setting Low Limit | 22 |
| Standard Accessories..... | 5 | Testing the Limits Switch Setup | 22 |
| Console Overview..... | 6 | Using Digital Load Limits..... | 23 |
| Column & Crosshead Overview | 7 | Connecting DF Series Force Gauge to LTCM Series..... | 23 |
| Travel Clearances..... | 7 | Using Older Firmware DF Series Gauges..... | 23 |
| Working Area | 8 | Using the Footswitch Controller | 24 |
| Extended Work Table Dimensions..... | 9 | Crosshead Direction Control | 24 |
| Getting Started | 11 | Using a Splinter Shield | 25 |
| Unpacking | 11 | Connecting the Splinter Shield | 25 |
| Setting up the LTCM force tester..... | 11 | Connecting a Personal Computer..... | 26 |
| Fixtures and Grip Adapters | 12 | RS232 Connection..... | 26 |
| Thread Adapters | 12 | USB Serial Connection..... | 26 |
| Eye Adapters | 12 | Mitutoyo Connection | 26 |
| Powering Your Tester | 14 | Performing Tensile Tests | 27 |
| Switching from 120V to 230V..... | 14 | Pull to Break Test | 27 |
| Changing Fuses..... | 15 | Pull to Force Limit Test..... | 28 |
| Using On/Off Switch | 16 | Pull to Deflection Limit Test..... | 29 |
| Using Emergency Stop Button | 16 | Performing Compression Tests | 30 |
| Connecting Your Gauge..... | 17 | Compress to Rupture Test..... | 30 |
| LTCM-100 Series..... | 17 | Compress to Force Limit Test..... | 31 |
| LTCM-500 Series..... | 17 | Compress to Deflection Limit Test | 32 |
| Connecting Remote SLC Sensor | 18 | Product Specifications | |
| LTCM-100 Series..... | 18 | LTCM-100 Series..... | 33 |
| LTCM-500 Series..... | 18 | LTCM-500 Series..... | 33 |
| SLC Sensor Dimensions | 19 | Dimension Drawings | |
| Using the Console Controls | 20 | LTCM-100 Series..... | 34 |
| Speed Selection Knob | 20 | LTCM-500 Series..... | 35 |
| Speed Units of Measure | 20 | Spare Parts | |
| Speed Display Window | 20 | LTCM-100 Series..... | 36 |
| Crosshead Travel Switch..... | 21 | LTCM-500 Series..... | 38 |
| Return Speed Selection Swtich | 21 | Troubleshooting Guide | 40 |
| MAX Speed Upward | 21 | | |
| MAX Speed Downward..... | 21 | | |
| NORMAL Speed Control | 21 | | |

Declaration of Conformity

A sample of this product has been assessed against the essential health and safety requirements of the Low Voltage and the EMC Directives listed. Based on conformity with the listed directives, this product is deemed in compliance with the following:

- BS EN 61010-1:2010 Safety Requirements for Electrical Equipment
- BS EN 61326-1:2006 Electrical equipment for measurement, control and laboratory use; General Requirements

Precautions

- Read the instruction manual completely before attempting to use the LTCM Series.** By following the instructions contained in this manual, the optimum accuracy and performance can be attained.
- Never operate the LTCM Series with the cover off.**
- Verify Input Power Source BEFORE operation.** The LTCM Series has a switchable power supply. The tester may operate with 115V or 230V provided the Power Input Module is in the proper setting corresponding to the source power. Always make sure that the supply power matches the setting on the Power Input Module before turning power ON. Failure to do so may cause serious damage to the tester.
- The LTCM Series has a moving crosshead!** Exercise extreme caution during testing or whenever the crosshead is moving. Never place fingers inside the column.
- Use Chatillon force gauges.** The LTCM Series is designed to be used safely with the Chatillon force gauges listed in this manual.
- Class 1 product must be connected to a mains socket outlet with a protective earth connection.**
- Place LTCM Series so that it is easy to access the power cord.**
- Never use the LTCM Series in a manner not specified by AMETEK.**
- Only use safety approved power cords that are supplied with the LTCM Series test machines.**

Product Warranty

This instrument is warranted against defects in workmanship, material and design for two (2) years from date of delivery to the extent that AMETEK will, at its sole option, repair or replace the instrument or any part thereof which is defective, provided, however, that this warranty shall not apply to instruments subjected to tampering or abuse, or exposed to highly corrosive conditions.

THIS WARRANTY IS IN LIEU OF ALL OTHER WARRANTIES WHETHER EXPRESSED OR IMPLIED AND AMETEK HEREBY DISCLAIMS ALL OTHER WARRANTIES, INCLUDING, WITHOUT LIMITATION, ANY WARRANTY OF FITNESS FOR A PARTICULAR PURPOSE OR MERCHANTABILITY. AMETEK SHALL NOT BE LIABLE FOR ANY INCIDENTAL OR CONSEQUENTIAL DAMAGES INCLUDING, BUT NOT LIMITED TO, ANY ANTICIPATED OR LOST PROFITS.

This warranty is voidable if the purchaser fails to follow any and all instructions, warnings, and cautions in the instrument's operating manual.

If a manufacturing defect is found, AMETEK will replace or repair the instrument or replace any defective part thereof without charge; however, AMETEK's obligation hereunder does not include the cost of transportation which must be borne by the customer. AMETEK assumes no responsibility for damage in transit, and any claim for such damage should be presented to the carrier by the purchaser.

Introduction

Introduction

Two CHATILLON® LTCM Series motorized test stands are available and covered by this operators' manual:

- LTCM-100 Series (110 lbf, 500N)
- LTCM-500 Series (550 lbf, 2500N)

LTCM Series motorized testers are designed to be use with Chatillon DF Series digital force gauges.

The LTCM Series has a compact design, making it ideal for the laboratory or production environment. The machine is designed for benchtop installations.

These testers are designed to operate in a vertical orientation and may be used for tensile, compression, peel, flexural or break tests.

Chatillon Force Gauges

The following Chatillon force gauges are recommended for use with the LTCM Series:

- DFX II Series (No Outputs)
- DFE II Series (With Outputs)
- DFS II Series (Integral Loadcell)
- DFS II R Series (Dedicated Remote Loadcell)
- DFS II R ND Series (With SLC Load Sensors)

Getting Started

Please read this operating manual thoroughly before attempting to operate your LTCM Series force tester.

The tables below identify the standard accessories that were supplied with your LTCM Series tester.

Standard Accessories



LTCM-100 Series

| Description | Part No. | Qty. |
|----------------------------------|----------------|------|
| Hook, Stationary, 110 lbf (500N) | SPK-FMG-012B | 1 |
| Compression Platen, 2-inch | 17109 | 1 |
| Hex Key, 5/32 | NC000846 | 1 |
| Gauge Mtg. Screws, #10-32 x 3/4 | 1613 | 2 |
| Power Cable, 115V, USA Plug | SPK-FM200-034 | 1 |
| Power Cable, 230V, EU Plug | SPK-FM200-022 | 1 |
| Power Cable, 230V, UK Plug | SPK-LTCM-UK230 | 1 |



LTCM-500 Series

| Description | Part No. | Qty. |
|-----------------------------------|----------------|------|
| Hook, Stationary, 550 lbf (2500N) | SPK-FMG-012C | 1 |
| Compression Platen, 3-inch | 17012 | 1 |
| Hex Key, 5mm | NC002924 | 1 |
| Hex Key, 5/32 | NC000846 | 1 |
| DF Gauge Adapter Plate | NC002905 | 1 |
| Gauge Mtg. Screws, #10-32 x 3/4 | 1613 | 4 |
| Power Cable, 115V, USA Plug | SPK-FM200-034 | 1 |
| Power Cable, 230V, EU Plug | SPK-FM200-022 | 1 |
| Power Cable, 230V, UK Plug | SPK-LTCM-UK230 | 1 |

Getting Started

Console Overview

The LTCM Series provides these functions on the tester's console:

- On/Off Switch
- Emergency Stop Switch
- Speed Units of Measure Selector Switch
- Speed Selector Knob
- Return Speed Switch
- Crosshead Direction of Travel Switch
- LED Display
- Speed Units Indicator

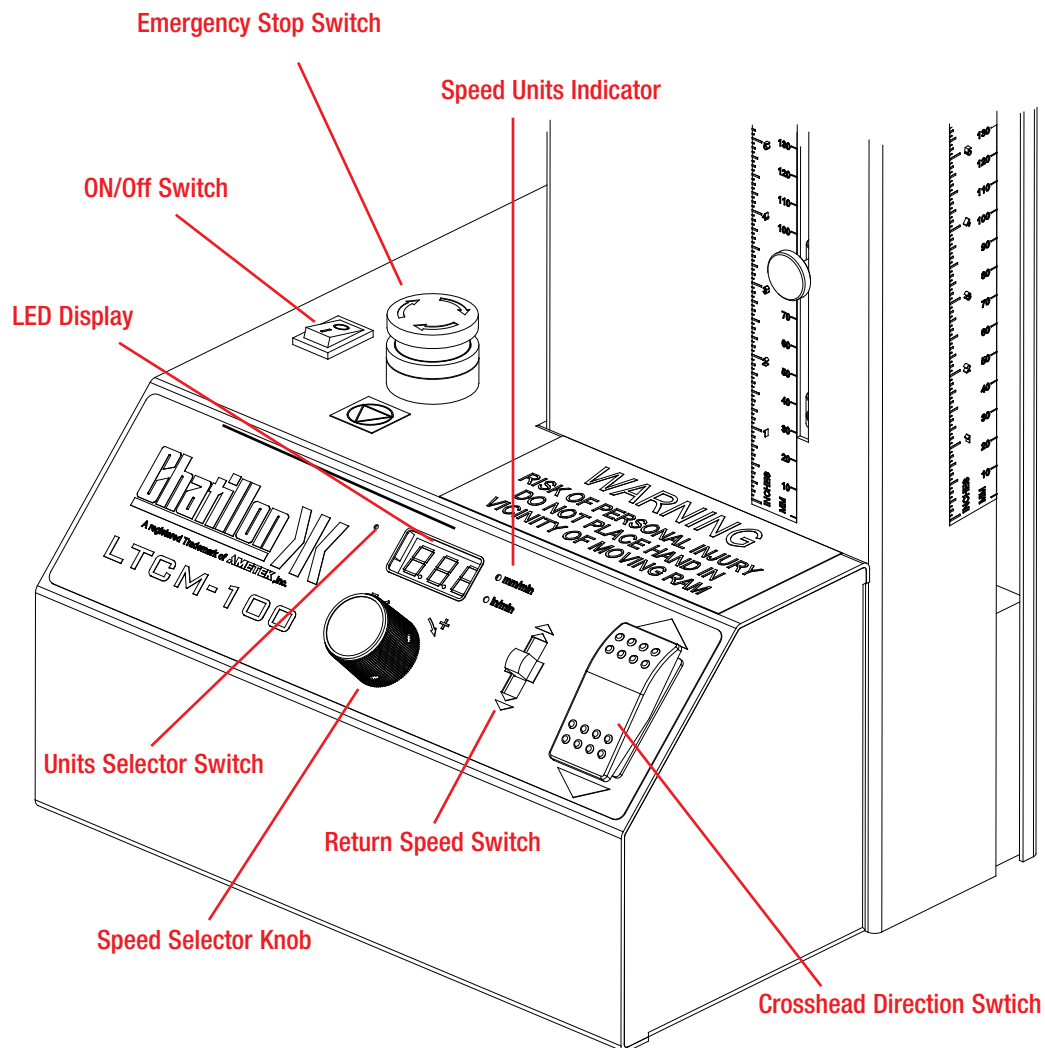

Column and Crosshead

The LTCM Series features a single column, designed to be used in a vertical position. Horizontal testing is not recommended.

The column features two mechanical limit switches mounted on the front. These switches may be manually adjusted to provide a High and Low Deflection stop, e.g. the crosshead will stop moving if the crosshead comes in contact with a limit.

The column also features two rulers for measuring deflection distance. The rulers have both inches and metric measurements.

The crosshead features a 5-1/8-inch (130 mm) throat. Combined with the large working area, it provides you with the ability to test large samples.

The crosshead moves in either direction. Crosshead speed is selected using the speed control knob located on the front of the console. Return speed may be independently set allowing the crosshead to return at the maximum speed setting.

The LTCM-100 crosshead contain two mounting holes. The Chatillon DF Series force gauge may be mounted directly to the crosshead.

The LTCM-500 crosshead contains four mounting holes. The Chatillon DF Series force gauge is mounted to the gauge adapter plate (p/n NC002905), which is mounted to the crosshead.

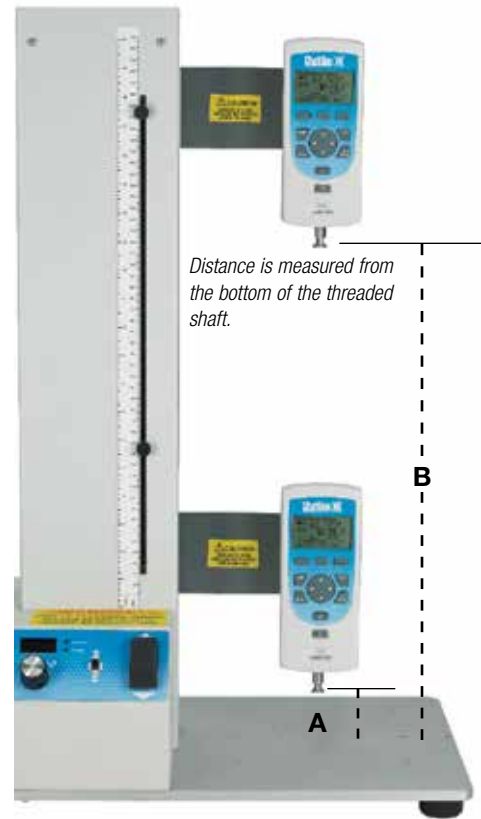

LTCM-100 Series

Column Specifications

| | | |
|--|---------------|---------------|
| Column Height | 26.4" (670mm) | |
| Maximum Crosshead Travel | 15.5" (394mm) | |
| Sample Heights with DF Series Gauges | A | B |
| DFE Series | 1.5" (38mm) | 17" (432mm) |
| E-DFE Series | 1.5" (38mm) | 17" (432mm) |
| DFS Series | 1.5" (38mm) | 17" (432mm) |
| DFS-R Series ¹ | 2" (51mm) | 17.5" (445mm) |
| SLC Series Sensor with DFS-R-ND ¹ | 2" (51mm) | 17.5" (445mm) |

LTCM-500 Series

Column Specifications

| | | |
|--|----------------|---------------|
| Column Height | 41.5" (1050mm) | |
| Maximum Crosshead Travel | 29.5" (750 mm) | |
| Sample Heights with DF Series Gauges | A | B |
| DFE Series | 2.2" (56mm) | 31.7" (805mm) |
| E-DFE Series | 2.2" (56mm) | 31.7" (805mm) |
| DFS Series | 2.2" (56mm) | 31.7" (805mm) |
| DFS-R Series ¹ | 2" (51mm) | 31.5" (800mm) |
| SLC Series Sensor with DFS-R-ND ¹ | 2" (51mm) | 31.5" (800mm) |

Notes: "A" is the minimal distance between the bottom of the gauge shaft and the tester base with the crosshead positioned at its "lowest" position. This represents the MINIMAL clearance between the gauge and the worksurface without loadcell shaft or fixtures attached.

"B" is the maximum distance between the bottom of the gauge shaft and the tester base with the crosshead positioned at its "highest" position. This represents the MAXIMUM clearance between the gauge and the worksurface without loadcell shaft or fixtures attached.

¹" The distance varies slightly depending on the remote SLC sensor used. Higher capacity sensors will reduce the clearance slightly.

Getting Started

Working Area

The LTCM Series testers have flexible work areas allowing for large size samples to be securely mounted and positioned for optimum measurement.

The LTCM-100 comes with a fixed extended work table ideal for testing samples up to 10-1/8-inches (257 mm) wide. The working platform is 10-1/8 x 11-inches (257 x 279 mm). The platform contains 13 pre-drilled holes with #10-32 threads. The multiple holes allow for a variety of testing fixtures and gripping sets to be used.

The LTCM-500 comes with a fixed T-slot table. A mounting block, consisting of four different mounting holes for various size adapters and fixtures is included. The holes sizes are:

- #10-32F
- 5/16-18F
- 1/4-28F
- M12 x 1.75F

There are alignment lines located on the T-slot table to help ensure that the hole centerline you are using is aligned with the force gauge or sensor attached to the crosshead. Simply slide the mounting block leading edge to the alignment line that corresponds with the hole size you are using. Tighten the two mounting screws. Thread in your adapter or fixture.

The LTCM-500 may be optionally equipped with an extended work table (p/n SPK-LTCM-067, similar to that used with the LTCM-100 Series). The working platform is 10-1/8 x 11-inches (257 x 279 mm). The platform contains 13 pre-drilled holes for fixtures. The holes have a 1/4-28F thread (different than the LTCM-100 Series).



The LTCM-100 comes standard with the expanded work table. The work table has 13 pre-drilled, #10-32 threaded holes for mounting fixtures and grip sets. The optional expanded work table for the LTCM-500 has 13 pre-drilled 1/4-28 holes.

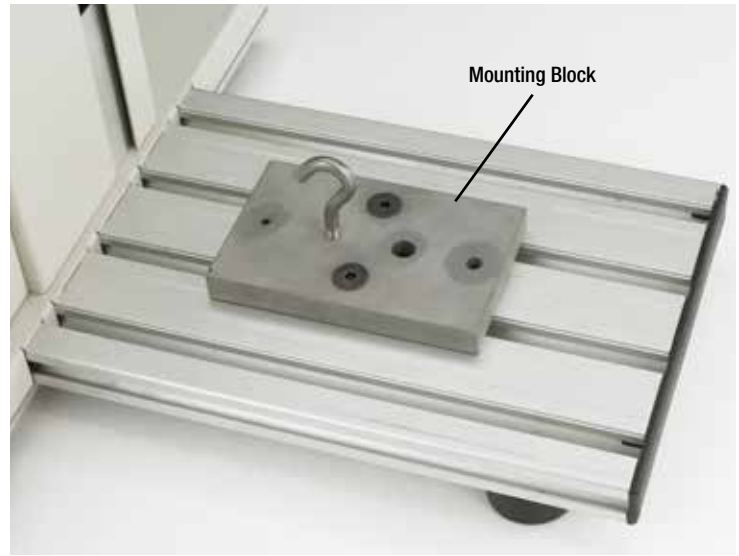

The LTCM-500 comes standard with a T-Slot table and adjustable mounting block. This permits flexible fixturing and the ability to ensure proper centerline alignment with the Chatillon DF Series force gauge.



The LTCM-100 with expanded work table. The expanded work table is standard on the LTCM-100 Series. The expanded work table is an option on the LTCM-500.

Dimensions, Expanded Work Tables

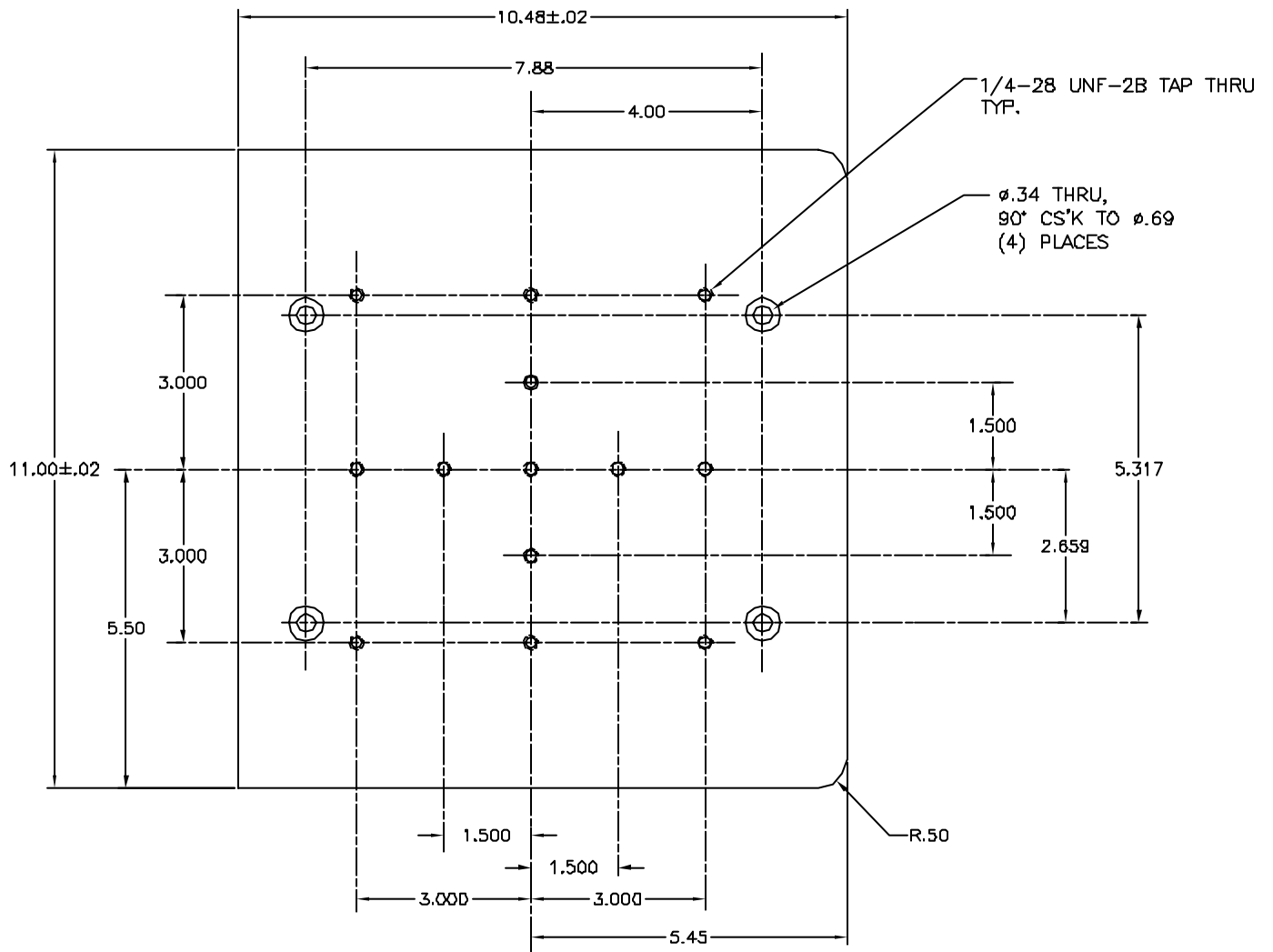

LTCM-500 Series Optional Extended Table Dimensions (p/n SPK-LTCM-067)

Getting Started

Dimensions, Expanded Work Tables

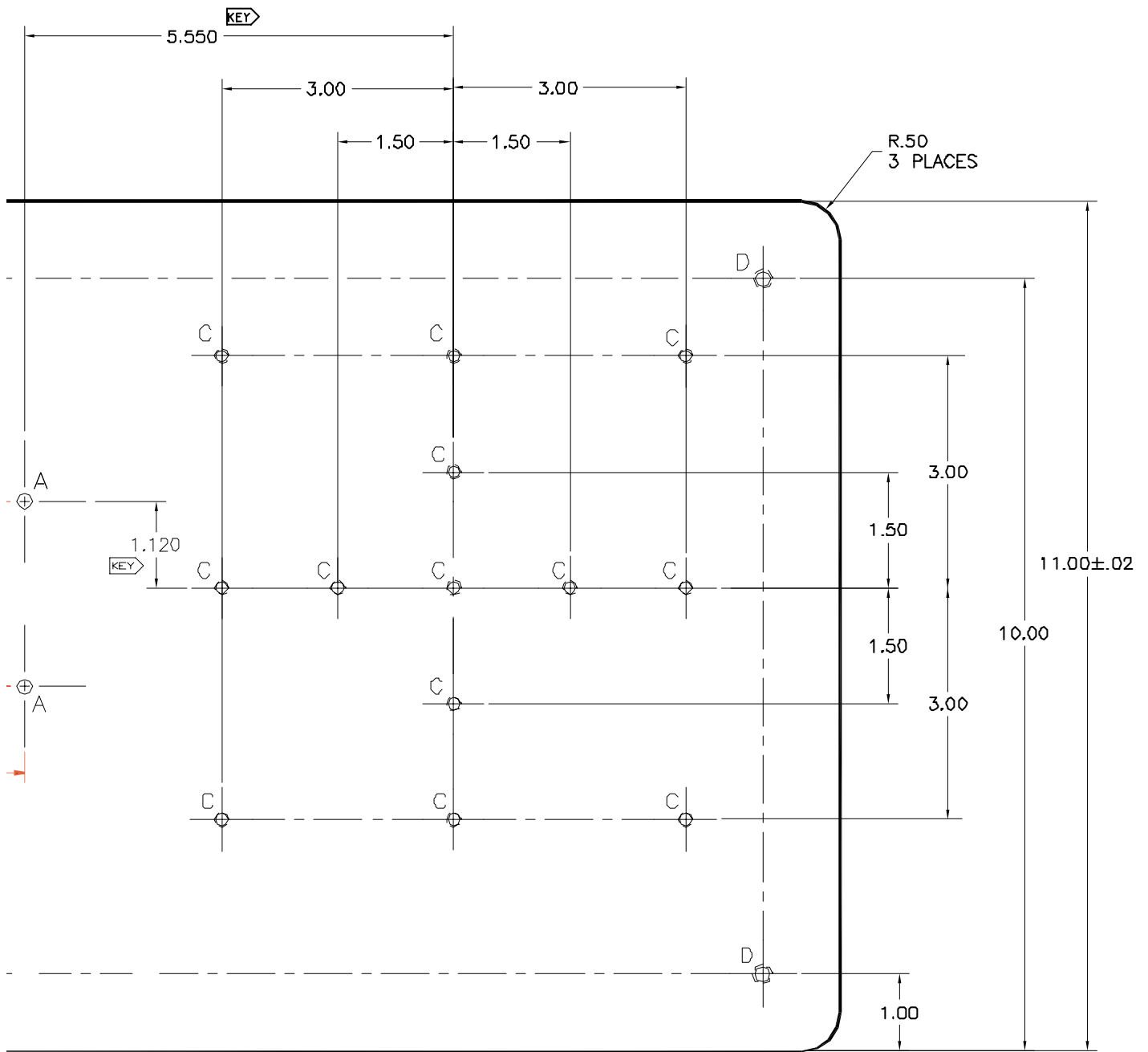

LTCM-100 Series Standard Work Table Dimensions

Unpacking

The LTCM Series testers are heavy objects and safe lifting practices should be employed when unpacking or moving the test machine.

The LTCM Series force testers are packed in a rugged shipping carton to minimize damage that may be caused from shipping mishandling. Please make a careful visual inspection of the force tester to ensure that there is no obvious transit damage to the equipment.

Setting up the LTCM force tester

The LTCM force tester should be placed on a stable bench or work surface that is capable of withstanding the test machine weight and fixtures. The LTCM-500 model is required to be mounted to a bench due to a potential tipping safety hazard. Use the hardware (T-nuts, M8xP1.25 screws and flat washers) provided to mount the LTCM-500 model from the T-slot table to the workbench prior to using the test machine. If the M8xP1.25 screws are not the correct length for the workbench thickness they must be replaced with suitable length screws.

Getting Started

Fixtures and Grip Adapters

The LTCM Series working platform is predrilled with 13 mounting holes.

The LTCM-100 mounting hole threads are #10-32F.

The LTCM-500 mounting hole threads are 1/4-28F.

A variety of grips and fixtures may be used with this working platform.

Listed below are the common adapters used to mount varying size fixtures and grips to the tester.

Eye Adapters - TG Series Fixtures

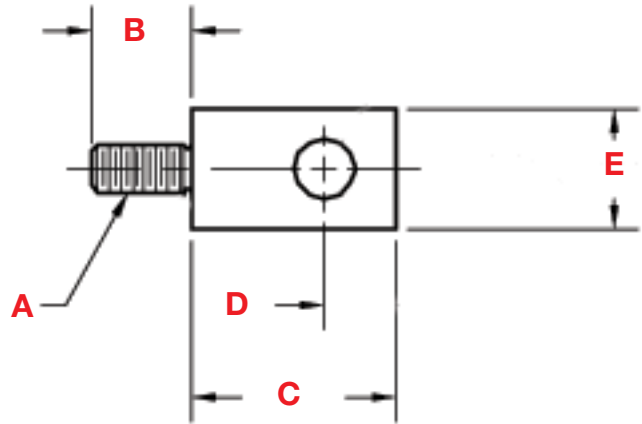

| Part No. | A | B | C | D | E |
|---------------|---------|---|---|---|------|
| SPK-EYE-1032M | #10-32M | | | | 5/8" |
| SPK-EYE-2520M | 1/4-20M | | | | 5/8" |
| SPK-EYE-2528M | 1/4-28M | | | | 5/8" |

Thread Adapters - GF Series Fixtures

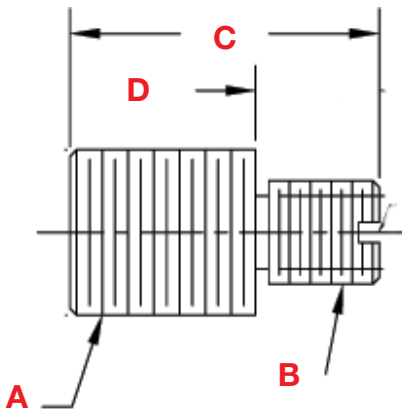

| Part No. | A | B | C | D |
|----------|---------|---------|--------|-------|
| 17039 | #10-32 | 1/4-28 | 1/2" | 5/16" |
| NC000686 | #10-32 | 5/16-18 | 3/4" | 1/4" |
| NC000296 | 1/4-28 | 5/16-18 | 7/8" | 3/8" |
| 17162 | 5/16-18 | 1/2-20 | 15/16" | 3/8" |

Eye Adapters - TG Series Fixtures

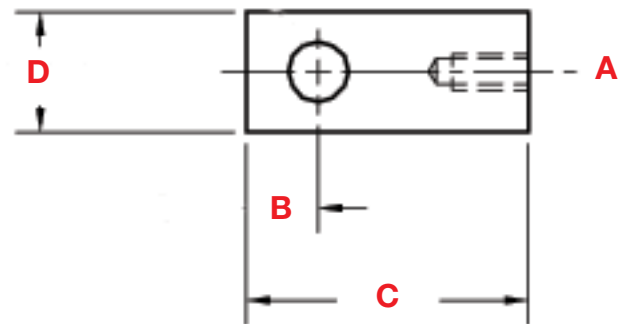

| Part No. | A | B | C | D |
|---------------|---------|---|---|------|
| SPK-EYE-1032F | #10-32F | | | 5/8" |
| SPK-EYE-2520F | 1/4-20F | | | 5/8" |

Gauge Adapters - TG Series Fixtures

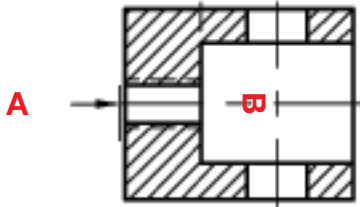

| Part No. | A | B |
|--------------|---------|------|
| SPK-AFG-1032 | #10-32F | 5/8" |
| SPK-AFG-2520 | 1/4-20F | 5/8" |
| SPK-AFG-2528 | 1/4-28F | 5/8" |

Powering Your Tester

Powering Your Tester

The CHATILLON® LTCM Series motorized test stands requires a stable 120V or 220V power source. The internal power transformer is switchable and operates at either 120V or 220V.

CAUTION

Always verify the Power Input Setting
BEFORE applying power to
the LTCM Series Tester.



Insert screwdriver into Power Entry Module slot. Carefully apply pressure to open the module.

Switch from 120V to 220V

The LTCM Series Power Entry Module contains an internal drum. This drum has four settings:

- 110Vac (Do NOT use)
- 120Vac (Use for standard 120V operation)
- 220Vac (Use for standard 220/230V operation)
- 240Vac (Do NOT use)

Use a flathead screwdriver to open the Power Entry Module. A small slot located at the top of the Power Entry Module locks the module closed. To unlock, position the screwdriver into the slot and carefully apply pressure.

To set the power input, remove the Power Drum by pulling the drum from its socket. **DO NOT ROTATE THE DRUM FROM WITHIN THE SOCKET.**

Reinsert the drum back into the socket so that respective power label matches your supply power. Close the Power Entry Module and make sure the correct label is displayed through the window.

CAUTION

Do NOT Rotate the Power Selection Drum while it is engaged in the Power Entry Module.
Remove the Drum and re-insert with the desired power showing thru the window.



Remove the Power Selector Drum from the socket. **DO NOT ROTATE THE POWER SELECTOR DRUM WHILE IN THE SOCKET.**

Changing Fuses

Two 1-Amp fuses are located inside the Power Input Module. Each fuse has its own compartment. To access these fuses, use a flat head screwdriver to open the module. Using the screwdriver, carefully slide the fuse access button in the direction of the arrow. The fuse will disengage and extend out for easy replacement.

Remove the fuse and replace with another 1-Amp fuse. Reinsert the fuse and re-insert the fuse holder back into the entry module position. Depress the arrow button to lock the fuse holder in place. **Note: Caution Double Pole/Neutral fusing.**

CAUTION

Use only 1-Amp fuses.
Do NOT use higher or lower ampere fuses.
Double Pole/Neutral Fusing



Place the side of the screwdriver next the fuse release button and apply slight pressure in the direction of the arrow.



Insert screwdriver into Power Entry Module slot. Carefully apply pressure to open the module.



Replace the 1-Amp fuse with another 1-Amp fuse. Reinsert the Fuse Module and depress the arrow button until it locks securely.

Replacement Fuses

| Model | Part No. | Description |
|-----------------|----------|---|
| LTCM-100 Series | E09-409 | 5mm diameter x 20mm length 1A, 250 Vac Slow Blow Fuse |
| LTCM-500 Series | E09-825 | 5mm diameter x 20mm length 3A, 250 Vac Fast Acting Fuse |

Turning Power On/Off

Using On/Off Switch

The LTCM Series has the On/Off switch located at the top of the console.

Depress the switch to turn the machine ON or OFF. When the machine is OFF, the speed indicator display is not illuminated.

When turning the machine OFF, you may note that it takes a few seconds for the speed indicator display to extinguish. This is due to the capacitor used to drive the display module.



The ON/OFF switch is a 2-way switch. The switch is lighted when power is ON.

Using Emergency Stop Button

The LTCM Series features an emergency stop button located at the top of the console. When this button is depressed, power is removed from the tester.

Activate Emergency Stop

To activate the emergency stop button, press firmly in a downward direction. The stop button will latch and lock into position.

Release the Emergency Stop

Power is returned to the tester when the emergency stop button is released to the UP position.

To release the emergency stop button, press firmly down on the stop button and turn in a clockwise direction. This will disengage the lock and return the stop button to its normal position.



Engage the Emergency OFF switch by pressing down on the red button. To disengage the emergency switch, press and turn counter clockwise. This will release the button to its normal position.

Connecting Your Chatillon Gauge

The LTCM Series has been designed for use with the Chatillon DF Series digital force gauges. The LTCM Series may also use the remote-style SLC Series load sensors.

The LTCM-100 crosshead has two (2) mounting holes. Use both holes to secure your Chatillon DF Series force gauge. The DF Series gauge may be mounted directly to the crosshead.

The LTCM-500 crosshead uses a gauge mounting plate (p/n [NC002905](#)) with four (4) mounting holes. All four mounting holes should be used when attaching a Chatillon DF Series force gauge to the crosshead.

LTCM-100 Series

The LTCM-100 crosshead has two (2) mounting holes. Use both holes to secure your Chatillon DF Series force gauge.

All DF Series gauges mount directly to the LTCM-100 Series tester using the two mounting holes located on the center of the force gauge. Use two (2) #10-32 socket head screws. Position the gauge in alignment with the through holes on the LTCM-100 Series crosshead. Screw through the crosshead into the gauge housing being careful not to cross-thread or screw too far into the gauge housing. The screw should extend into the gauge housing no more than 0.4-inches (10mm).

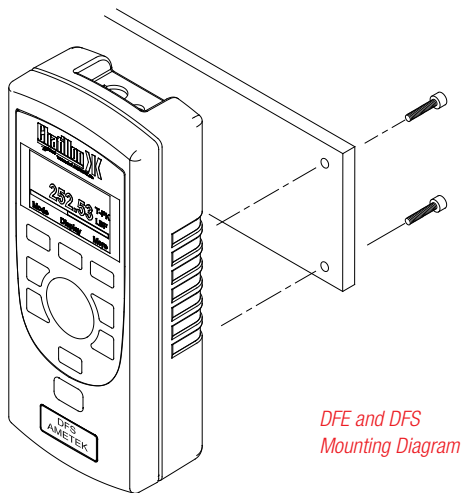

DFE and DFS
Mounting Diagram

LTCM-500 Series

The LTCM-500 crosshead uses a gauge mounting plate (p/n [NC002905](#)) with four (4) mounting holes. All four mounting holes should be used when attaching a Chatillon DF Series force gauge to the crosshead.

All DF Series gauges mount directly to the Gauge Mounting Plate (p/n [NC002905](#)) which is attached to the LTCM-500 crosshead. The Gauge Mounting Plate contains four (4) holes. Use four (4) #10-32 socket head screws. Position the gauge in alignment with the through holes on the LTCM-500 Series Gauge Mounting Plate. Screw through the mounting plate and crosshead into the gauge housing being careful not to cross-thread or screw too far into the gauge housing. The screw should extend into the gauge housing no more than 0.4-inches (10mm).

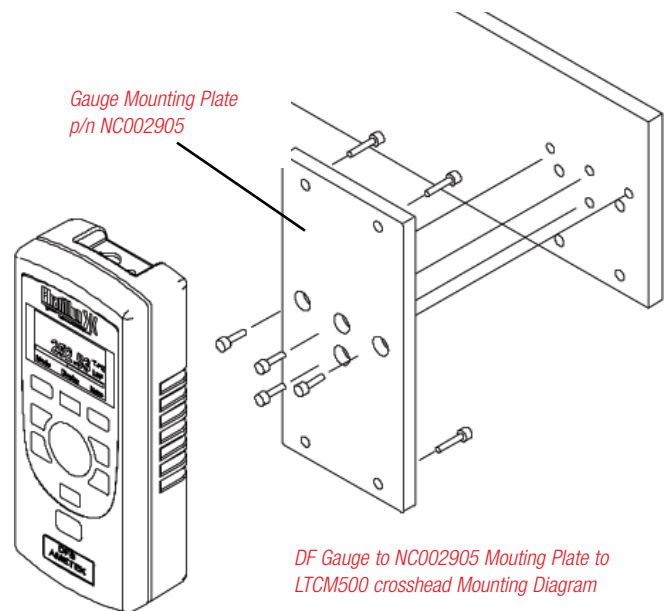

DF Gauge to NC002905 Mounting Plate to
LTCM500 crosshead Mounting Diagram

CAUTION

Screws should NOT penetrate into the DF Series housing more than 0.4 inch (10 mm). Inserting to greater depth may damage internal components.

Attaching Remote SLC Style Sensors

LTCM-100 Series

When mounting a remote style SLC Series load sensor on the LTCM-100 Series, you must use the Remote Sensor Adapter (p/n **NC000300**).

All SLC Series (used with DFS-R gauges) S-type loadcell sensors mount to the LTCM-100 Series using the Remote Sensor Adapter.

First affix the loadcell sensor to the mounting adapter. A socket head screw is used to position the sensor tightly to the bracket.

Use two (2) #10-32 socket head screws to mount the bracket to the LTCM-100 Series crosshead.

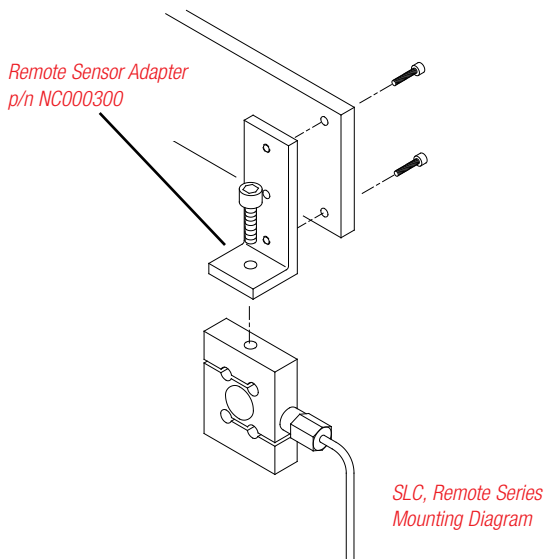

LTCM-500 Series

The LTCM-500 crosshead can be fitted with a special Remote Sensor Adapter Kit (p/n **SPK-LTCM-066**). This special adapter kit has been designed for capacities up to 550 lbf (2500N). This adapter comes with three (3) different mounting threads (set screws) allowing you to attach these thread sizes:

- ❑ #10-32F
- ❑ 1/4-28F
- ❑ 1/2-20F

Four (4) #10-32 x 3/4-inch mounting screws are included to attach the Remote Sensor Adapter block to the LTCM-500 crosshead.

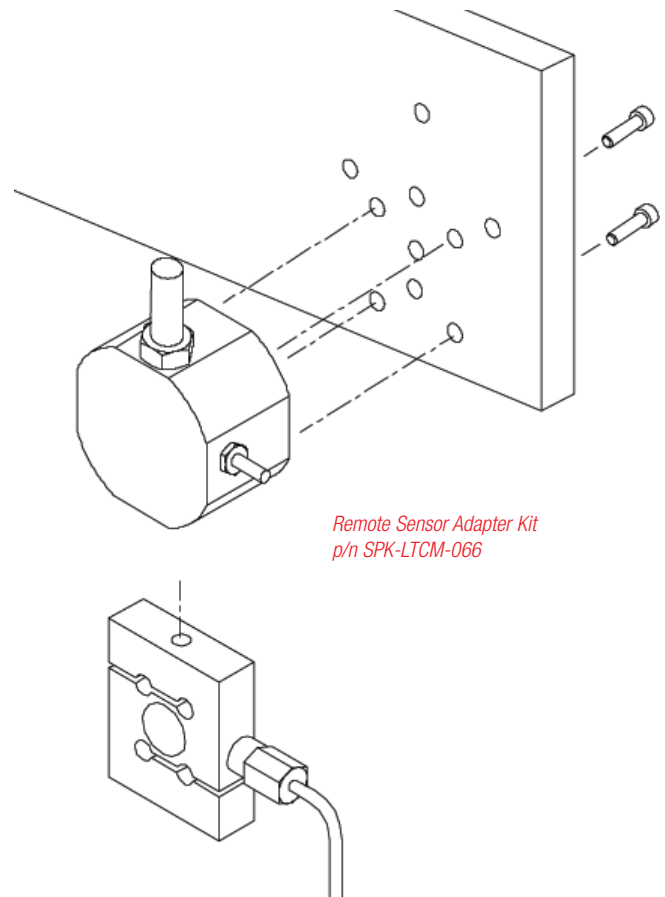

SLC Series Sensor Dimensions

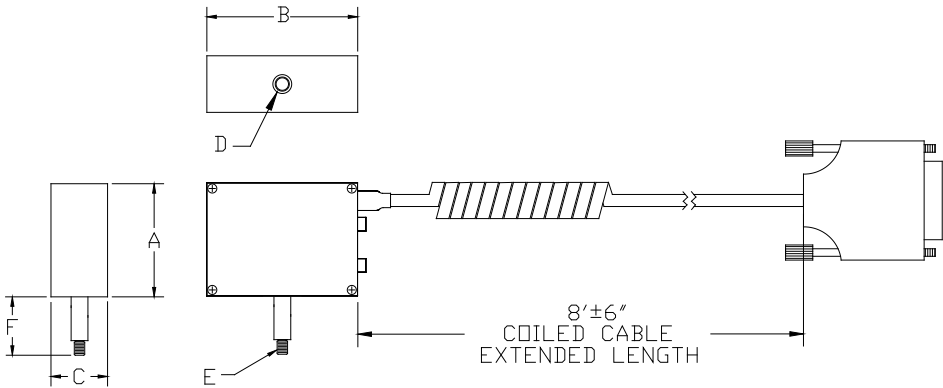

| | | | | | | |
|----------|-------------|-------------|------------|-----------------------|---------------------|-----|
| 25 LBF | 1.50 [38.1] | 2.00 [50.8] | .75 [19.0] | #10-32 | #10-32 | .75 |
| 10 LBF | 1.50 [38.1] | 2.00 [50.8] | .75 [19.0] | #10-32 | #10-32 | .75 |
| 2 LBF | 1.50 [38.1] | 2.00 [50.8] | .75 [19.0] | #10-32 | #10-32 | .75 |
| 250 G | 1.50 [38.1] | 2.00 [50.8] | .75 [19.0] | #10-32 | #10-32 | .75 |
| CAPACITY | A | B | C | D FEMALE THREAD | E MALE THREAD | F |

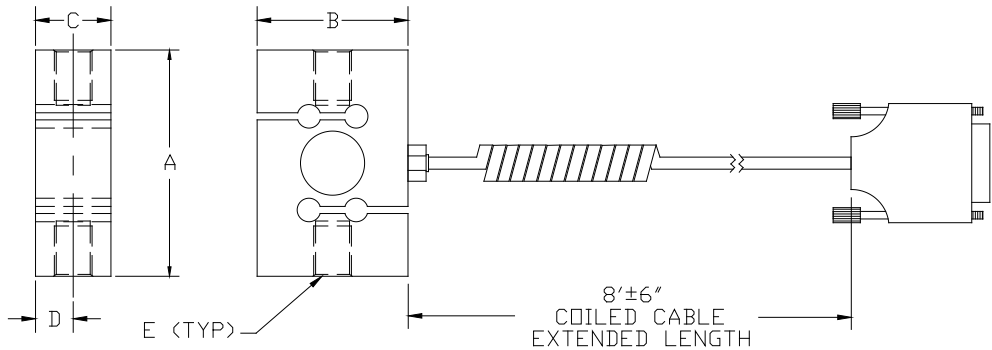

| | | | | | |
|----------|-------------|-------------|------------|------------|-------------|
| 1000 LBF | 2.98 [75.7] | 2.50 [63.5] | .98 [24.9] | .49 [12.4] | 1/2-20 |
| 500 LBF | 2.98 [75.7] | 2.00 [50.8] | .98 [24.9] | .49 [12.4] | 1/2-20 |
| 200 LBF | 2.48 [63.0] | 2.00 [50.8] | .61 [15.5] | .31 [7.9] | 1/4-28 |
| 100 LBF | 2.48 [63.0] | 2.00 [50.8] | .61 [15.5] | .31 [7.9] | 1/4-28 |
| 50 LBF | 2.48 [63.0] | 2.00 [50.8] | .61 [15.5] | .31 [7.9] | 1/4-28 |
| CAP. | A | B | C | D | E THREAD |

E96-355

Using Console Controls

Using the Console Controls

The LTCM Series has been designed for simple operation. Controls are intuitive and easy to use. This section will describe how to use the various Console Controls.

Speed Selection Knob

The LTCM Series has a speed selection knob which corresponds to speed display. Rotating the knob will adjust the crosshead speed and the corresponding speed will be indicated on the LED display.

Increase the speed by rotating the knob clockwise.

Decrease the speed by rotating the knob counter-clockwise.

During a test, when the crosshead is moving, the Speed Selection Knob is disengaged. Rotating the knob during a test will not change the speed of the crosshead.

CAUTION

Do NOT attempt to change the crosshead speed during a test. When the crosshead is moving, the Speed Selection Knob is disengaged.

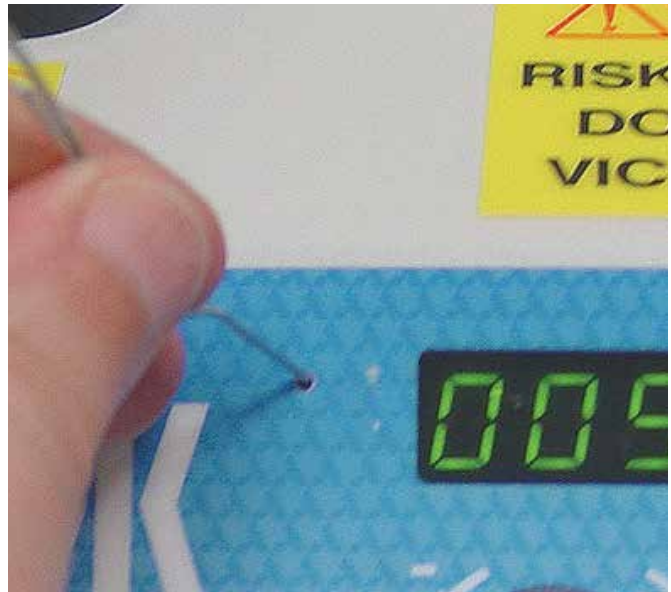

Speed Units of Measurement Selection

The LTCM Series can display speed in inches per minute (in/min) or in millimetres/min (mm/min).

To specify the Units of Measure required, turn the tester power OFF.

Insert a small diameter probe into the Units Selector Switch and depress the internal switch and HOLD. Turn the power ON. The LTCM Series will indicate the Units of Measure by the LED indicator. Disengage probe when the correct units of speed is indicated.

Speed Display

The LTCM Series display is a 7-segment LED indicator. The speed shown is associated with the Units of Measure that is also indicated by an LED status light.

The displayed speed corresponds to the Speed Selector Knob.

The Speed Display indicates the speed setting.

CAUTION

The Speed Display requires about 5 seconds to completely discharge when the power is turned OFF.

Do NOT power the tester OFF and immediately turn the tester ON.

Allow at least 5 seconds from when you turn the tester OFF before you turn the tester ON.

Crosshead Travel Switch

The LTCM Series crosshead travel is controlled by the Travel Switch. This is a momentary switch that is depressed to engage the crosshead and motor mechanism to drive the internal leadscrew.

To move the crosshead in an UPWARD direction, depress and hold the Travel Switch in an UPWARD direction (top).

To move the crosshead in a DOWNWARD direction, depress and hold the Travel Switch in a DOWNWARD direction (bottom).

Return Speed Selection Switch

The LTCM Series features an independent return switch. The switch has three settings:

- Normal
- Maximum Speed Upward
- Maximum Speed Downward

Maximum Speed Upward

When the Return Speed Switch is set to the “Maximum Speed Upward” setting (top), the Speed Travel Switch will cause the UPWARD direction to travel at maximum speed. Depressing the switch down will cause the crosshead to travel at the displayed speed shown in the Speed Display window.

Maximum Speed Downward

When the Return Speed Switch is set to the “Maximum Speed Downward” setting (bottom), the Speed Travel Switch will cause the DOWNWARD direction to travel at maximum speed. Depressing the switch up will cause the crosshead to travel at the displayed speed shown in the Speed Display window.

Normal Setting

When the Return Speed Switch is set to the center, the return speed is the same as the Speed Selection display. Depressing the Travel Switch will cause the crosshead to move at the selected speed indicated on the display in both the UP and DOWN directions.



Using Mechanical Limits

Using Mechanical Limits

The LTCM Series has adjustable mechanical limits that are designed to help protect your force gauge from overloads. These limits are called extension or deflection limits and are designed to stop the machine's crosshead travel when the internal microswitch is contacted by the crosshead.

The front of the LTCM Series column features a ruler with two adjustable mechanical limits switches. One switch is for the HIGH Limit. The other switch is for the LOW Limit. The limit switches should be positioned using the ruler, so that the crosshead will stop when contact is made with the High or Low switch.

Setting HIGH Limit

Limits are supplied to protect your force gauge. The HIGH Limit protects the force gauge's sensor by preventing the crosshead from traveling beyond your limit value.

The HIGH Limit is designed to protect the gauge when the crosshead is in the UPWARD travel direction.

To set the limit, loosen the thumbscrew by turning the screw in a counter-clockwise direction. You only need to loosen the screw enough so that the switch slides along the internal guide. When the screw is loose, slide the mechanism to the desired extension position. Tighten the screw by turning clockwise.

Test your setting using a slow crosshead speed, e.g. 0.4 in/min. Move the crosshead in an UPWARD direction and watch to see where the crosshead makes contact and ensure that contact with the limit switch stopped the crosshead travel. If the crosshead stops too soon or too late, adjust the thumbscrew, reposition the limit mechanism and repeat the test.

Setting LOW Limit

The LOW Limit is designed to protect the gauge when the crosshead is in the DOWNWARD travel direction.

To set the limit, loosen the thumbscrew by turning the screw in a counter-clockwise direction. You only need to loosen the screw enough so that the switch slides along the internal guide. When the screw is loose, slide the mechanism to the desired extension position. Tighten the screw by turning clockwise.

Test your setting using a slow crosshead speed, e.g. 0.4 in/min. Move the crosshead in an DOWNWARD direction and watch to see where the crosshead makes contact and ensure that contact with the limit switch stopped the crosshead travel. Adjust accordingly.



If the thumbscrew is completely disconnected from the limit switch, carefully position the limit switch so that the threaded end points outward through the limit switch slot. Thread the thumbscrew into the limit switch being careful to avoid cross-threading. Do not over tighten the thumbscrew. "Finger tight" is sufficient to hold the switch in place.

CAUTION

Always test the action of the Limit Switch whenever you make a change to their position on the column.

Testing the Limit Switch

Once you have positioned your Limit Switch, test to ensure that it is operating properly.

Lower Limit Switch Test

Drive the crosshead in a downward direction. While the crosshead is moving downward, press downward on the lower Limit Switch. The crosshead should stop moving.

Upper Limit Switch Test

Drive the crosshead in an upward direction. While the crosshead is moving upward, press the upper Limit Switch upward. The crosshead should stop moving.

Switch Engagement

Check to ensure that the crosshead engages both the Upper and Lower Limit Switches during its travel. You should hear a "click" when the crosshead makes contact with the switch. The crosshead should stop moving.

Using Digital Load Limits

The LTCM Series can accept a Load Limit signal from your Chatillon DF Series force gauge. When the DF Series gauge is setup with Load Limits, the gauge will send a signal to the LTCM Series tester when the Load Limit has been achieved, causing the crosshead to stop moving.

The Load Limit is designed to protect the DF Series force gauge or SLC Sensor from an overload condition, or to alert the operator when a Load Limit condition has been met. When a Load Limit is sensed, the LTCM Series tester will display “LLL” alternately with the crosshead “Set Speed”.

When the DF Series force gauge or SLC Series Load Sensor senses a Load Limit, there is a slight time delay between when the actual Load Limit is detected by the gauge/sensor and when it is “read” by the tester. Depending on the tester speed, you may encounter slight crosshead movement when a Load Limit is sensed due to electronic transmission and inertia. This is normal. You may compensate for this delay if you cannot have any crosshead overshooting by manipulating your actual Load Limit setpoint to correspond to where you want the crosshead to stop.

Connecting your DF Series Force Gauge

The Chatillon DF Series force gauge is connected to the LTCM Series tester using the gauge interface cable (p/n ENC0125).

Make sure that power is Off at both the force gauge and the LTCM Series tester when connecting a cable.

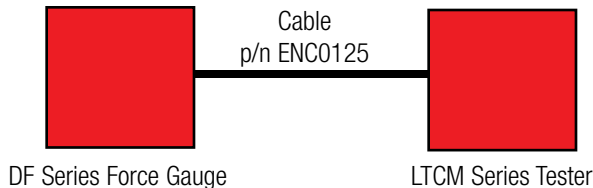

Using Older Version Firmware

Chatillon DF Series force gauges manufactured prior to May 2006 (check Calibration Certificate supplied with your gauge) have an older style printed circuit board (PCB). In order to make use of load limits with the LTCM Series, you must position jumper at J3.

Follow this procedure to reposition the jumper setup.

1. Make sure that the DF Series gauge is connected to the LTCM Series tester using cable p/n ENC0125.
2. Make sure that Power to the LTCM Series is OFF. Disconnect the power cord to the LTCM Series tester.
3. Remove the Console Cover on the LTCM Series to expose the tester electronics. Six screws are fastened through the Console Baseplate to secure the Console Cover. (4 screws on LTCM-100)
4. At the I/O PC Board, locate Jumper J3. The default jumper position is 1-2. Change this position to 2-3.

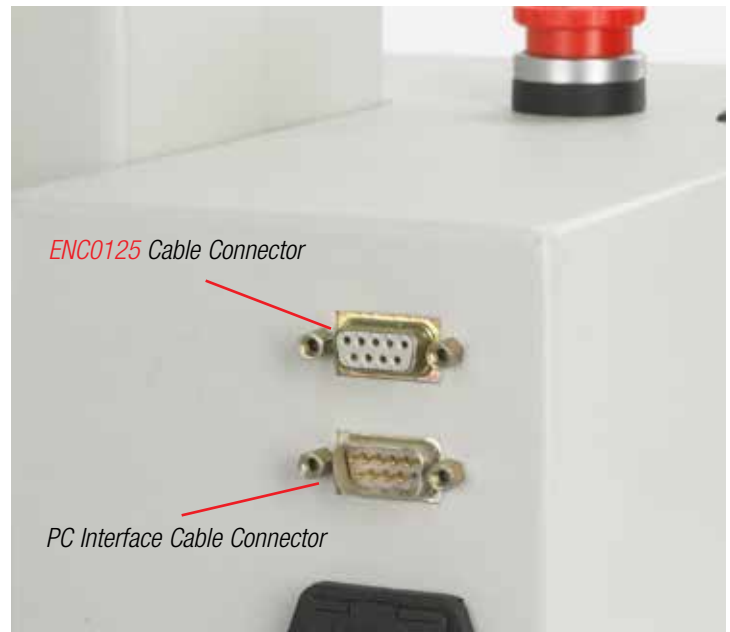

Make sure that power to the LTCM Series tester is Off. Carefully connect cable ENC0125 to the LTCM Series tester. The cable connects to the UPPER 9-Pin connector.

5. Reassemble the Console Cover onto the Console Baseplate.
6. Reconnect the Power cable to the LTCM Series tester.
7. Turn Power to the LTCM Series tester to ON.
8. Make sure Power to the DF Series force gauge is ON.

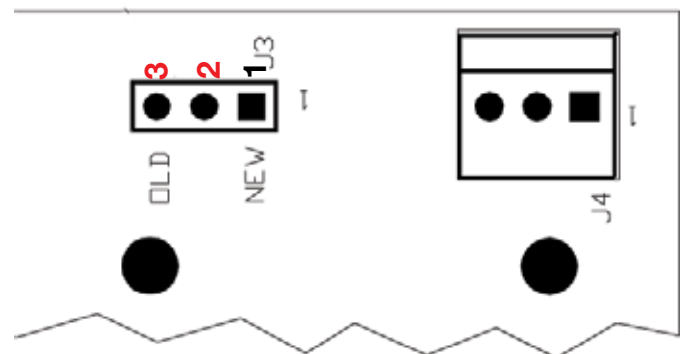

To use Load Limits with older version Chatillon DF Series force gauges, you must change the J3 jumper position from 1-2 to 2-3. When you change the J3 position, power to the gauge must be ON and the gauge must be connected to the LTCM Series using cable ENC0125. If jumper is moved to 2-3, the gauge must be ON and CONNECTED.

Using Remote Footswitch

Using Remote Footswitch

The LTCM Series can be equipped with the optional remote footswitch for controlling the crosshead movement.

The Remote Footswitch (p/n **NC002910**) plugs into the rear of the LTCM Series console at the stereo input jack.

CAUTION

Do NOT plug the Remote Footswitch into the Console while the crosshead is moving.

AMETEK recommends that the power to the LTCM Series tester be Off BEFORE connecting the Footswitch Controller.



Make sure power is Off at the LTCM Series tester before inserting the remote Footswitch Controller. The Footswitch Controller has a 8 foot (2.5m) length cable with stereo jack connector. The connector is inserted into the back of the LTCM Series console.

Crosshead Direction Control

The right pedal on the Footswitch Controller causes the crosshead to move in an UPWARD direction. Press and hold to move the crosshead. Release the foot pedal to stop the crosshead movement.

The left pedal on the Footswitch Controller causes the crosshead to move in a DOWNWARD direction. Press and hold to move the crosshead. Release the foot pedal to stop the crosshead movement.

Pressing the right and left pedal simultaneously causes the crosshead to stop.

Using Splinter Shield

The LTCM-500 Series may be equipped with the optional Splinter Shield (p/n [NC002927](#)). The Splinter Shield is designed to contain testing materials to within the work area.

The Splinter Shield is manufactured of Lexan. It is supplied assembled.

CAUTION

The Splinter Shield is NOT intended to be used as a personal safety device. It is designed to contain materials under test, within the work area.

ALWAYS wear safety glasses when performing a test.

Connecting the Splinter Shield

1. Remove the Top Cap on the column by removing the four holding screws.
2. Remove the front end cap on the T-Slot table.
3. Slide the T-Nuts in the outer slots on the T-Slot table.
4. Align the top mounting holes on the Splinter Shield with the mounting holes on the column (front and back).
5. Re-install the Top Cap making sure to align the holes so that the screws secure the top of the Splinter Shield with the top of the column.
6. Tighten and T-Nut screws so that the T-Nuts fit snugly to the T-Slot Table.

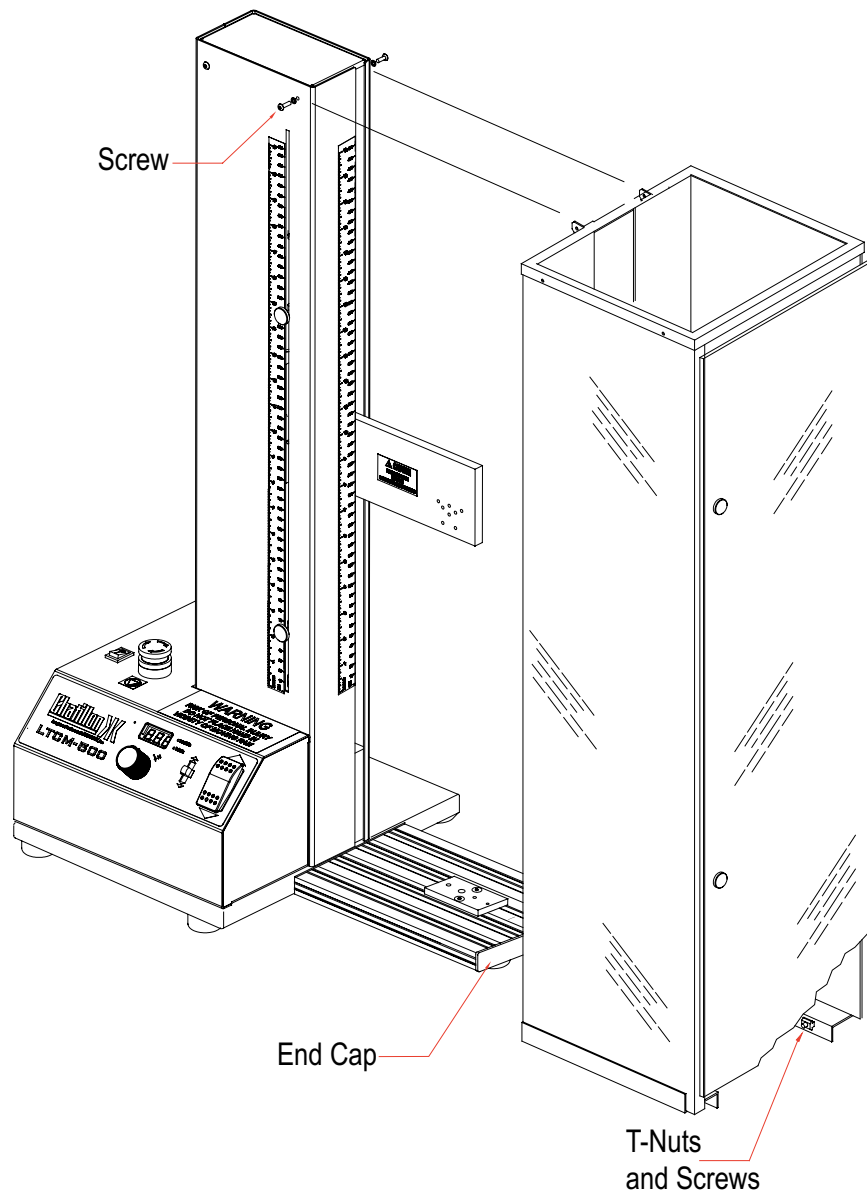

Connecting to a Personal Computer

Connecting to a Personal Computer

The LTCM Series has no RS232 or serial data communications, therefore it cannot be controlled by a personal computer, nor can it provide data corresponding to deflection or extension values.

However, you may use Nexygen DF Software (p/n [NC002867](#)) to collect and analyze your load versus time data for a test.

Connect Using RS232 Cable

Connect to a personal computer using a 9-pin RS232 cable (p/n [NC000875](#)). This cable will connect to the LOWER 9-pin connector located on the back of the LTCM Series console and to your RS232 9-pin connector on your personal computer.

Connect Using USB Cable

Connect to a personal computer using a USB serial cable (p/n [SPK-DF-USB](#)) in combination with [NC000875](#). Connect [NC000875](#) to [SPK-DF-USB](#). Connect USB connector to personal computer.

Connect Using Mitutoyo Cable

Connect to a Mitutoyo device, such as a Mitutoyo DP1-VR data recorder using two special Mitutoyo cables.

Connect the DF Series force gauge to the LTCM Series tester using [ENC0125](#).

Connect the LTCM Series tester to the Mitutoyo device using cable (p/n [ENC0157](#)).

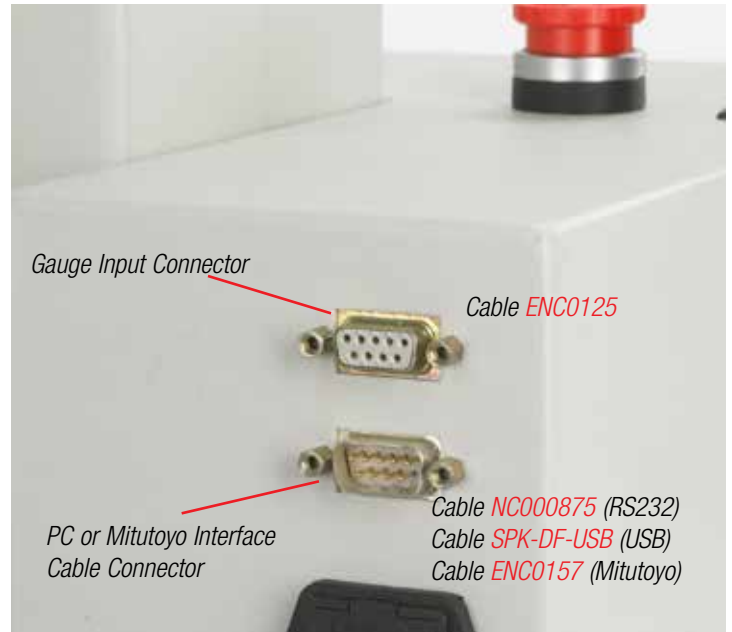

The LOWER 9-Pin connector is used for interfacing to a personal computer, e.g. when you are using Nexygen DF software and are collecting and analyzing load versus time data. Use cable [NC000875](#).

CAUTION

The LTCM Series has
NO SERIAL COMMUNICATIONS ability.

The 9-pin computer interface connector on the back of the console serves as a split signal interface to the DF Series force gauge.

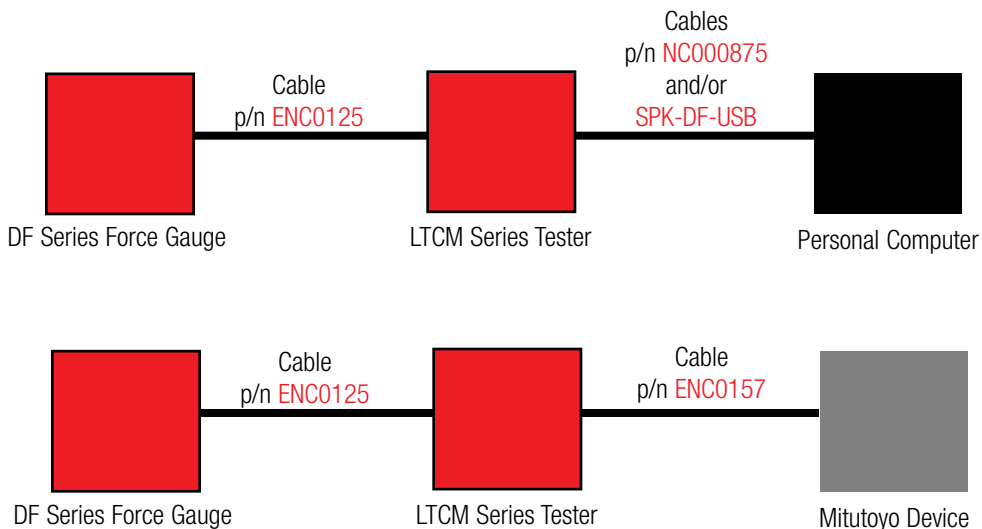

Performing a Tensile Test

The LTCM Series may be used to perform tensile tests.

Common tensile tests are:

- Pull to Break
- Pull to Force Limit
- Pull to Deflection Limit

Pull to Break

Use a Chatillon DFS Series digital force gauge to perform a Pull to Break Test. The DFS Series has a Break Detection function that allows you to define your break parameters. This function is especially useful for samples that yield prior to breaking.

Mount the appropriate testing fixture for holding your sample to your DFS Series gauge and to the center mounting hole on the LTCM Series work surface.

With the DFS Series mounted to the LTCM Series crosshead, first set the mechanical limits on your LTCM Series. Position the HIGH and LOW limits to ensure that your DFS is protected from accidental overloads. Allow enough distance between the the HIGH and LOW limits to ensure that the sample breaks.

Select the speed Units of Measure. The units that correspond to the Speed Display are highlighted with an LED status indicator. Use the Speed Units switch to change if necessary to inches/min or mm/min.

Select the test speed. Rotate the dial until the speed for your test is displayed in the Speed window.

Set the Return Speed Switch to the desired setting; Normal or Maximum Downward. Since the crosshead will be moving upward during a tensile test, it may be advantageous to set the Return Speed to Maximum downward. Position the switch in the down position.

Secure your sample to the fixture on the gauge first. Then use the down key to lower the crosshead so that the sample can be secured to the lower fixture (LTCM Series).

Remove excess “slack” with the sample, however, being careful not to apply a load to the DFS force gauge.

Zero the DFS force gauge.

Note the zero deflection value using the ruler on the LTCM Series column. This will be useful if you are doing repetitive testing, since you can return the crosshead to the same location at the completion of a test.

Depress the Travel Switch in the UPWARD direction and observe that the crosshead is moving UPWARD. As the crosshead moves UPWARD tension is applied to the sample.

Continue pressing the Travel Switch upward until the sample breaks.

The DFS Series gauge will display the peak tensile force for the test and the break force for the test based on your “break criterion”.

Return the crosshead by depressing the Travel Switch DOWNWARD. Since the Return Speed Switch is set to Maximum DOWNWARD, the crosshead will return at maximum speed.

Performing a Test

Pull to Force Limit

Use a Chatillon E-DFE or DFS Series digital force gauge to perform a Pull to Force Limit Test. In this test, your gauge will be setup to provide Load Limits. Load Limits are designed to alert the operator when the measured force has exceeded a HIGH or LOW Load Limit. The gauges will provide you with an audible and visual annunciator.

Mount the appropriate testing fixture for holding your sample to your DF Series gauge and to the center mounting hole on the LTCM Series work surface.

With the DF Series mounted to the LTCM Series crosshead, first set the mechanical limits on your LTCM Series. Position the HIGH and LOW limits to ensure that your DF Series is protected from accidental overloads. Allow enough distance between the the HIGH and LOW limits to ensure that the sample can get to the desired limit.

Select the speed Units of Measure. The units that correspond to the Speed Display are highlighted with an LED status indicator. Use the Speed Units switch to change if necessary to inches/min or mm/min.

Select the test speed. Rotate the dial until the speed for your test is displayed in the Speed window.

Set the Return Speed Switch to the desired setting; Normal or Maximum Downward. Since the crosshead will be moving upward during a tensile test, it may be advantageous to set the Return Speed to Maximum downward. Position the switch in the down position.

Connect the force gauge to the LTCM Series tester using cable ENC0125.

Secure your sample to the fixture on the gauge first. Then use the down key to lower the crosshead so that the sample can be secured to the lower fixture (LTCM Series).

Remove excess “slack” with the sample, however, being careful not to apply a load to the DF Series force gauge.

Zero the DF Series force gauge.

Note the zero deflection value using the ruler on the LTCM Series column. This will be useful if you are doing repetitive testing, since you can return the crosshead to the same location at the completion of a test.

Depress the Travel Switch in the UPWARD direction and observe that the crosshead is moving UPWARD. As the crosshead moves UPWARD tension is applied to the sample.

Continue pressing the Travel Switch upward until the DF Series indicates the desired force. The DF gauge will also provide you with an audible (if gauge Buzzer option is ON) and visual indication that the limit has been achieved.

The DF Series gauge will display the peak tensile force for the test.

Measure your deflection distance using the ruler.

Return the crosshead by depressing the Travel Switch DOWNWARD. Since the Return Speed Switch is set to Maximum DOWNWARD, the crosshead will return at maximum speed.

CAUTION

ALWAYS assume some over-travel once a load limit or deflection limit is achieved.

Use the slowest speed possible if over-travel must be kept to a minimum. This counters the effect of inertia and electronic transmission speed requirements.

Pull to Deflection Limit

Use a Chatillon DFE or DFS Series digital force gauge to perform a Pull to Deflection Limit Test. In this test, your crosshead will travel from a zero point to a deflection limit. You will be using distance to drive a force. In this test, it is important to carefully measure your zero deflection point and your end point. You can use the Upper Limit Switch to define your Deflection Limit point.

Mount the appropriate testing fixture for holding your sample to your DF Series gauge and to the center mounting hole on the LTCM Series work surface.

With the DF Series mounted to the LTCM Series crosshead, first set the mechanical limits on your LTCM Series. Position the HIGH and LOW limits to ensure that your DF Series is protected from accidental overloads. Allow enough distance between the the HIGH and LOW limits to ensure that the sample can get to the desired limit.

Select the speed Units of Measure. The units that correspond to the Speed Display are highlighted with an LED status indicator. Use the Speed Units switch to change if necessary to inches/min or mm/min.

Select the test speed. Rotate the dial until the speed for your test is displayed in the Speed window.

Set the Return Speed Switch to the desired setting; Normal or Maximum Downward. Since the crosshead will be moving upward during a tensile test, it may be advantageous to set the Return Speed to Maximum downward. Position the switch in the down position.

Secure your sample to the fixture on the gauge first. Then use the down key to lower the crosshead so that the sample can be secured to the lower fixture (LTCM Series).

Remove excess "slack" with the sample, however, being careful not to apply a load to the DF Series force gauge.

Zero the DF Series force gauge.

Note the zero deflection value using the ruler on the LTCM Series column. This will be useful if you are doing repetitive testing, since you can return the crosshead to the same location at the completion of a test.

Depress the Travel Switch in the UPWARD direction and observe that the crosshead is moving UPWARD. As the crosshead moves UPWARD tension is applied to the sample.

Continue pressing the Travel Switch upward until the crosshead makes contact with the Upper Limit Switch. The crosshead will stop automatically. Observe the force displayed by the gauge.

The DF Series gauge will display the peak tensile force for the test.

Return the crosshead by depressing the Travel Switch DOWNWARD. Since the Return Speed Switch is set to Maximum DOWNWARD, the crosshead will return at maximum speed.

CAUTION

ALWAYS assume some over-travel once a load limit or deflection limit is achieved.

Use the slowest speed possible if over-travel must be kept to a minimum. This counters the effect of inertia and electronic transmission speed requirements.

Performing a Test

Performing a Compression Test

The LTCM Series may be used to perform compression tests on test samples with capacities of up to 110 lbf (500 N). With compression testing, it is very important to protect your gauge from accidental overloads.

Common compression tests are:

- Compress to Rupture (Break)
- Compress to Force Limit
- Compress to Deflection Limit

Compress to Rupture

Use a Chatillon DFS Series digital force gauge to perform a Compress to Rupture test. The DFS Series has a Break Detection function that allows you to define your break parameters. This function is especially useful for samples that yield prior to breaking.

Mount the appropriate testing fixture to your DFS Series gauge. Generally, this is a probe, platen or grip adapter for compression testing.

With the DFS Series mounted to the LTCM Series crosshead, first set the mechanical limits on your LTCM Series. Position the LOW limit to ensure that your DFS is protected from accidental overloads. Allow enough distance between the the HIGH and LOW limits to ensure that the sample breaks. The LOW Limit is critical and should be positioned to protect your gauge from an overload caused by the crosshead moving too far after the break.

Select the speed Units of Measure. The units that correspond to the Speed Display are highlighted with an LED status indicator. Use the Speed Units switch to change if necessary to inches/min or mm/min.

Select the test speed. Rotate the dial until the speed for your test is displayed in the Speed window.

Set the Return Speed Switch to the desired setting; Normal or Maximum Upward. Since the crosshead will be moving downward during a compression test, it may be advantageous to set the Return Speed to Maximum upward. Position the switch in the up position.

Secure your sample to the fixture on the gauge first. Then use the down key to lower the crosshead so that the sample can be secured to the lower fixture (LTCM Series).

Zero the DF Series force gauge.

Note the zero deflection value using the ruler on the LTCM Series column. This will be useful if you are doing repetitive testing, since you can return the crosshead to the same location at the completion of a test.

Depress the Travel Switch in the DOWNWARD direction and observe that the crosshead is moving DOWNWARD. As the crosshead moves DOWNWARD compression is applied to the sample.

Continue pressing the Travel Switch downward until the sample breaks.

The DFS Series gauge will display the peak compression force for the test and the break force for the test based on your “break criterion”.

Return the crosshead by depressing the Travel Switch UPWARD. Since the Return Speed Switch is set to Maximum UPWARD, the crosshead will return at maximum speed.

Compress to Force Limit

Use a Chatillon E-DFE or DFS Series digital force gauge to perform a Compress to Force Limit Test. In this test, your gauge will be setup to provide Load Limits. Load Limits are designed to alert the operator when the measured force has exceeded a HIGH or LOW Load Limit. The gauges will provide you with an audible and visual annunicator.

Mount the appropriate testing fixture for your compression test. Generally, the fixture is a probe, platen or flat adapter.

With the DF Series mounted to the LTCM Series crosshead, first set the mechanical limits on your LTCM Series. Position the LOW Limit Switch so that it protects your gauge from accidental overloading. The LOW Limit Switch should be positioned just beyond the projected load limit deflection point.

Connect the force gauge to the LTCM Series tester using cable ENC0125.

Select the speed Units of Measure. The units that correspond to the Speed Display are highlited with an LED status indicator. Use the Speed Units switch to change if necessary to inches/min or mm/min.

Select the test speed. Rotate the dial until the speed for your test is displayed in the Speed window.

Set the Return Speed Switch to the desired setting; Normal or Maximum Upward. Since the crosshead will be moving downward during a compression test, it may be advantageous to set the Return Speed to Maximum upward. Position the switch in the up position.

Zero the DF Series force gauge.

Note the zero deflection value using the ruler on the LTCM Series column. This will be useful if you are doing repetitive testing, since you can return the crosshead to the same location at the completion of a test.

Depress the Travel Switch in the DOWNWARD direction and observe that the crosshead is moving DOWNWARD. As the crosshead moves DOWNWARD compression is applied to the sample.

Continue pressing the Travel Switch downward until the DF Series indicates the desired force. The DF gauge will also provide you with an audible (if gauge Buzzer option is ON) and visual indication that the limit has been achieved.

The DF Series gauge will display the peak compression force for the test.

Measure your deflection distance using the ruler.

Return the crosshead by depressing the Travel Switch UPWARD. Since the Return Speed Switch is set to Maximum UPWARD, the crosshead will return at maximum speed.

CAUTION

ALWAYS assume some over-travel once a load limit or deflection limit is achieved.

Use the slowest speed possible if over-travel must be kept to a minimum. This counters the effect of inertia and electronic transmission speed requirements.

Performing a Test

Compress to Deflection Limit

Use a Chatillon DFE or DFS Series digital force gauge to perform a Compress to Deflection Limit Test. In this test, your crosshead will travel from a zero point to a deflection limit. You will be using distance to drive a force. In this test, it is important to carefully measure your zero deflection point and your end point. You can use the Lower Limit Switch to define your Deflection Limit point.

Mount the appropriate testing fixture to your DF Series gauge. Generally, the fixture is a probe, platen or flat adapter.

With the DF Series mounted to the LTCM Series crosshead, first set the mechanical limits on your LTCM Series. Position the LOW limit at the desired deflection point that will end the test.

Select the speed Units of Measure. The units that correspond to the Speed Display are highlighted with an LED status indicator. Use the Speed Units switch to change if necessary to inches/min or mm/min.

Select the test speed. Rotate the dial until the speed for your test is displayed in the Speed window.

Set the Return Speed Switch to the desired setting; Normal or Maximum Upward. Since the crosshead will be moving downward during a compression test, it may be advantageous to set the Return Speed to Maximum upward. Position the switch in the up position. Zero the DF Series force gauge.

Note the zero deflection value using the ruler on the LTCM Series column. This will be useful if you are doing repetitive testing, since you can return the crosshead to the same location at the completion of a test.

Depress the Travel Switch in the DOWNWARD direction and observe that the crosshead is moving DOWNWARD. As the crosshead moves DOWNWARD compression is applied to the sample.

Continue pressing the Travel Switch downward until the crosshead makes contact with the Lower Limit Switch. The crosshead will stop automatically. Observe the force displayed by the gauge.

The DF Series gauge will display the peak compressive force for the test.

Return the crosshead by depressing the Travel Switch UPWARD. Since the Return Speed Switch is set to Maximum UPWARD, the crosshead will return at maximum speed.

CAUTION

ALWAYS assume some over-travel once a load limit or deflection limit is achieved.

Use the slowest speed possible if over-travel must be kept to a minimum. This counters the effect of inertia and electronic transmission speed requirements.

LTCM-100 Series

Load Capacity: 110 lbf (500N)
Travel: 15.5-inches (394 mm)
Speed Range: 0.2 to 20.0 inches per minute
5 to 510 mm/min
Speed Accuracy: $\pm 3\%$ Full Scale (unloaded)
Frame Deflection: Less than 0.025" at full load capacity
Measurement System: Chatillon DF Series Digital Force Gauge
Operating Temperature: 45⁰ to 110⁰F (8⁰ to 45⁰C)
Storage Temperature: 0⁰ to 130⁰F (-17⁰ to 54⁰C)
Power
Voltage: 115Vac $\pm 10\%$ or 230Vac $\pm 10\%$
Frequency: 50/60 Hz
Current: 1 Amp Maximum
Relative Humidity: 20% to 85%
Tester Weight: 39 lbs (17.7 kg) approximate
Shipping Weight: 48 lbs (22 kg) approximate

LTCM-500 Series

Load Capacity: 550 lbf (2500N)
Travel: 29.5-inches (750 mm)
Speed Range: 0.2 to 20.0 inches per minute
5 to 510 mm/min
Speed Accuracy: $\pm 3\%$ Full Scale (unloaded)
Frame Deflection: Less than 0.065" at full load capacity
Measurement System: Chatillon DF Series Digital Force Gauge
Operating Temperature: 45⁰ to 110⁰F (8⁰ to 45⁰C)
Storage Temperature: 0⁰ to 130⁰F (-17⁰ to 54⁰C)
Power
Voltage: 115Vac $\pm 10\%$ or 230Vac $\pm 10\%$
Frequency: 50/60 Hz
Current: 1 Amp Maximum
Relative Humidity: 20% to 85%
Tester Weight: 100 lbs (45 kg) approximate
Shipping Weight: 120 lbs (55 kg) approximate

Dimensions

LTCM-100 Series

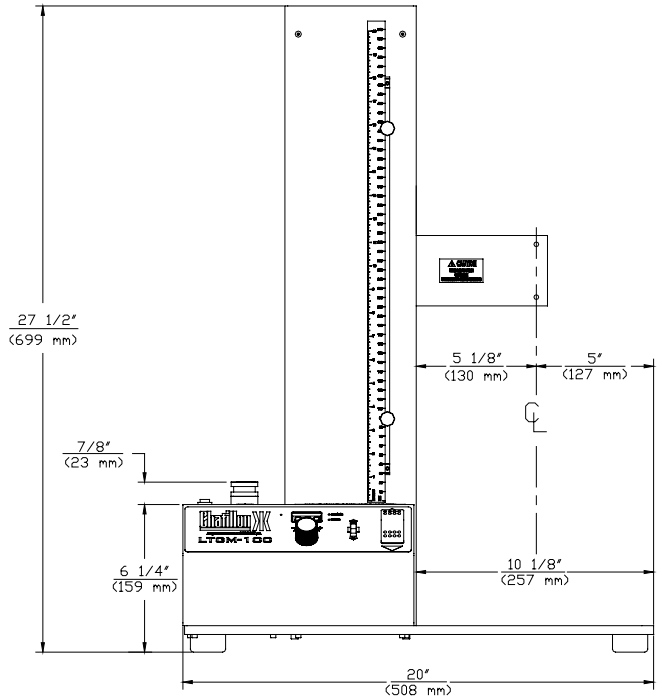
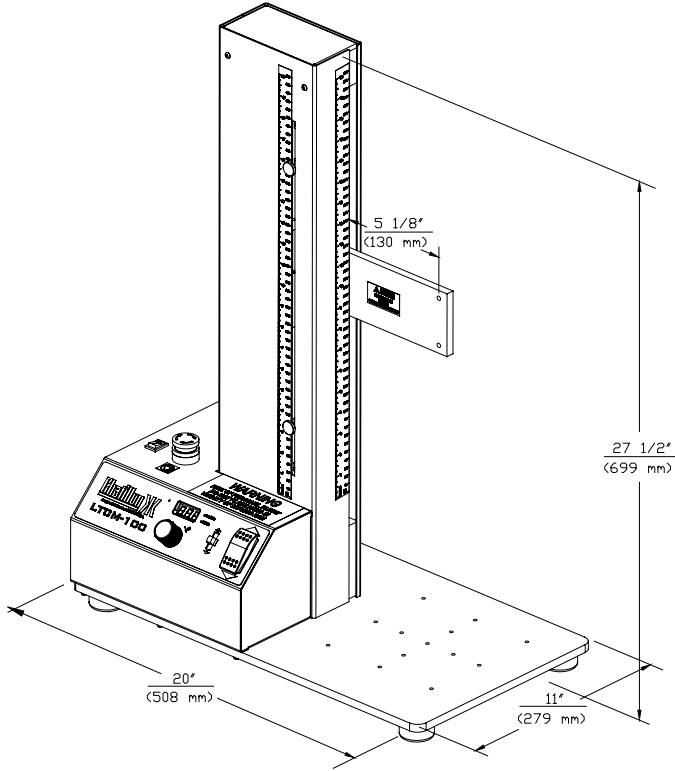

E96-359

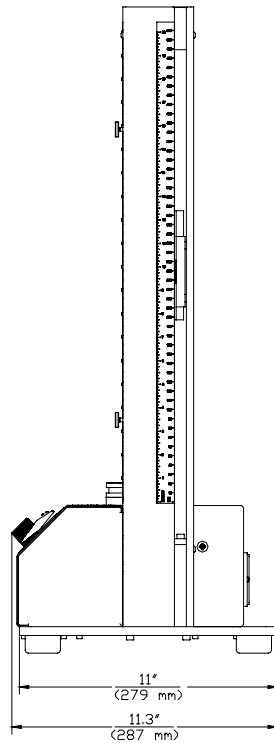

LTCM-500 Series

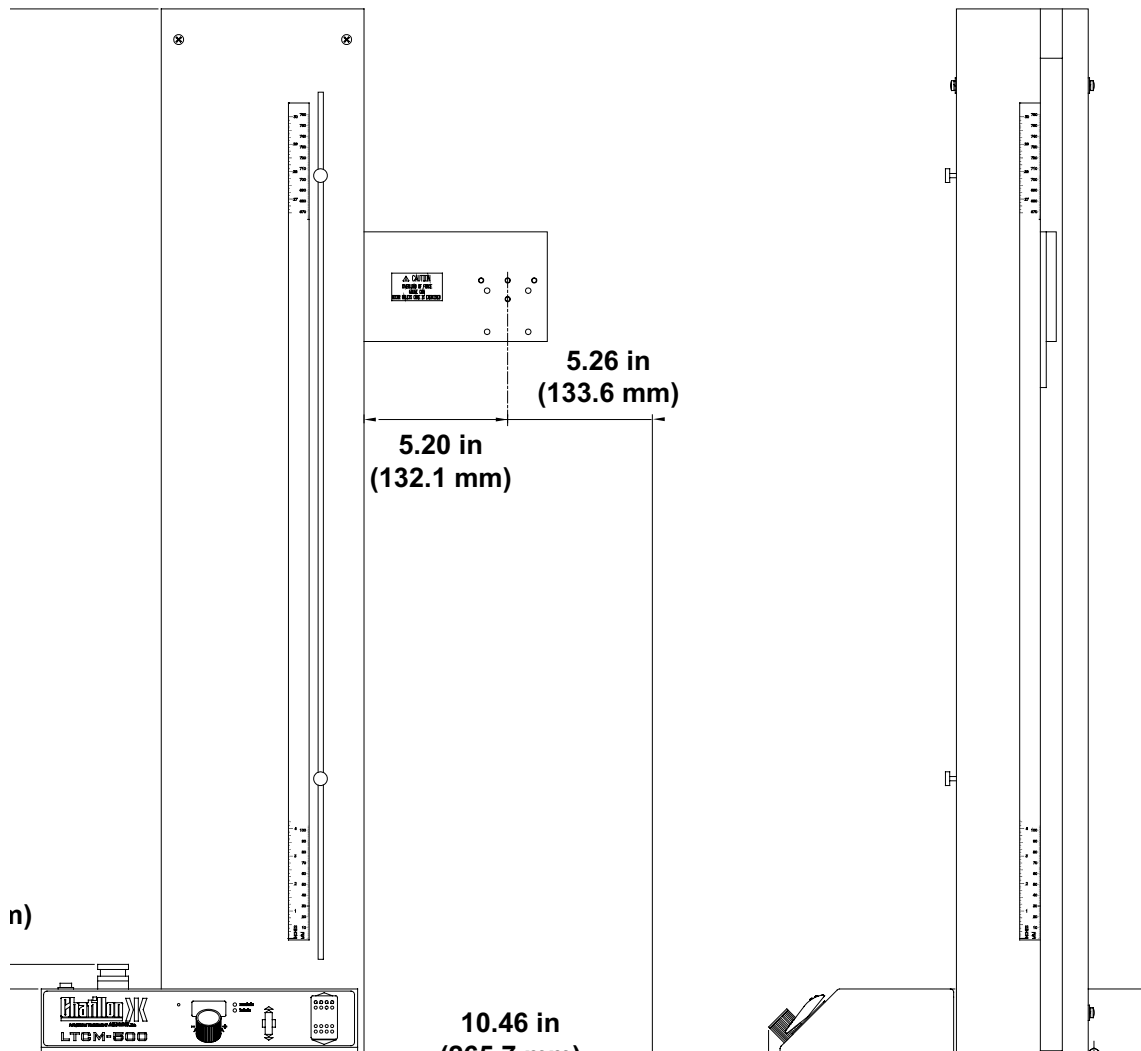

Spare Parts

LTCM-100 Series Spare Parts

| Ref. | Part Number | Description |
|------|--------------|----------------------------------|
| 1 | SPK-LTCM-001 | Cover Assembly |
| 2 | SPK-LTCM-002 | Overlay, LTCM Series |
| 3 | SPK-LTCM-003 | Ruler, Label, 20-inch |
| 4 | SPK-LTCM-004 | Printed Circuit Board Assembly |
| 5 | SPK-LTCM-005 | On/Off Switch |
| 6 | SPK-LTCM-006 | Switch, Emergency |
| 7 | SPK-LTCM-007 | Transformer Assembly |
| 8 | SPK-LTCM-008 | Power Entry Module Assembly |
| 9 | SPK-LTCM-009 | Knob, Plastic |
| 10 | SPK-LTCM-010 | Up/Down Switch Assembly |
| 11 | SPK-LTCM-011 | Cable, Encoder |
| 12 | SPK-LTCM-012 | Base Plate Assembly |
| 13 | SPK-LTCM-013 | Feet and Fasteners |
| 14 | SPK-LTCM-014 | Timing Belt |
| 15 | SPK-LTCM-015 | Pulley, Motor |
| 16 | SPK-LTCM-016 | Pulley, Ball Screw |
| 17 | SPK-LTCM-017 | Plate, Motor Mounting |
| 18 | SPK-LTCM-018 | Motor, with Mounting Screws |
| 19 | SPK-LTCM-019 | Limit Switch Assembly |
| 20 | SPK-LTCM-020 | Ball Screw Assembly |
| 21 | SPK-LTCM-021 | Bearing |
| 22 | SPK-LTCM-022 | Bearing, Retainer Plate Kit |
| 23 | SPK-LTCM-023 | Rod, Bushing |
| 24 | SPK-LTCM-024 | Bushing |
| 25 | SPK-LTCM-025 | Sleeve Bearing |
| 26 | SPK-LTCM-026 | Encoder |
| 27 | SPK-LTCM-027 | Rod, Limit Switch |
| 28 | SPK-LTCM-028 | Collar with Set Screw |
| 29 | SPK-LTCM-029 | Sleeve |
| 30 | SPK-LTCM-030 | Crosshead Travel Adjustment Knob |
| 31 | SPK-LTCM-031 | Column, Front Panel |
| 32 | SPK-LTCM-032 | Column, Front Panel Assembly |
| 33 | SPK-LTCM-033 | Column, Rear Panel |
| 34 | SPK-LTCM-034 | Crosshead |
| 35 | SPK-LTCM-035 | Label Kit |
| | E09-409 | Fuse, 1A, 250Vac, Fast Acting |

Parts highlighted in **RED** are common to both the LTCM-100 and LTCM-500

LTCM-100 Series Spare Parts

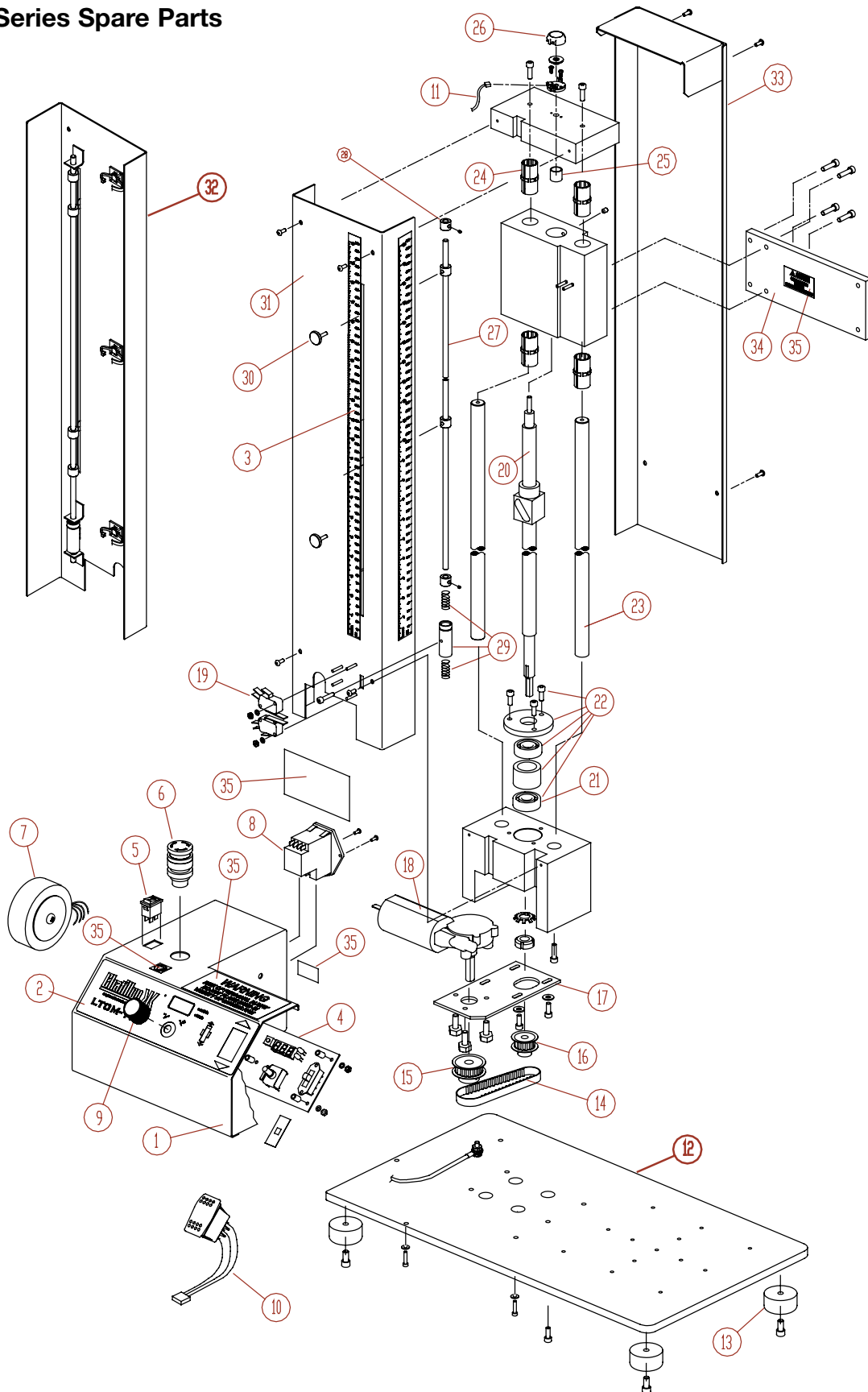

Spare Parts

LTCM-500 Series Spare Parts

| Ref. | Part Number | Description |
|------|--------------|---------------------------------------|
| 1 | SPK-LTCM-005 | On/Off Switch |
| 2 | SPK-LTCM-006 | Emergency Switch |
| 3 | SPK-LTCM-008 | Power Entry Module Assembly |
| 4 | SPK-LTCM-009 | Knob, Plastic |
| 5 | SPK-LTCM-010 | Up/Down Switch Assembly |
| 6 | SPK-LTCM-019 | Limit Switch Assembly |
| 7 | SPK-LTCM-026 | Encoder |
| 8 | SPK-LTCM-028 | Collar and Set Screw |
| 9 | SPK-LTCM-030 | Crosshead Travel Adjustment Rod |
| 10 | SPK-LTCM-036 | Cover Assembly |
| 11 | SPK-LTCM-037 | Overlay, LTCM-500 |
| 12 | SPK-LTCM-038 | Printed Circuit Board |
| 13 | SPK-LTCM-039 | Transformer Assembly |
| 14 | SPK-LTCM-040 | Printed Circuit Board, Interface |
| 15 | SPK-LTCM-041 | Cable, Printed Circukt Board Assembly |
| 16 | SPK-LTCM-042 | Cable, Up/Down Switch Kit |
| 17 | SPK-LTCM-043 | Ruler, 30-inch |
| 18 | SPK-LTCM-044 | Base, Fixture Mount |
| 19 | SPK-LTCM-045 | End Cap |
| 20 | SPK-LTCM-046 | Motor and Hardware |
| 21 | SPK-LTCM-047 | Pulley, Motor |
| 22 | SPK-LTCM-048 | Plate, Motor Mount |
| 23 | SPK-LTCM-049 | Pulley, Ball Screw |
| 24 | SPK-LTCM-050 | Timing Belt |
| 25 | SPK-LTCM-051 | Feet and Fasteners |
| 26 | SPK-LTCM-052 | Ball Screw Assembly |
| 27 | SPK-LTCM-053 | Bearings |
| 28 | SPK-LTCM-054 | Arm, Crosshead |
| 29 | SPK-LTCM-055 | Label Package |
| 30 | SPK-LTCM-056 | Shaft |
| 31 | SPK-LTCM-057 | Bushing |
| 32 | SPK-LTCM-058 | Cable, Encoder |
| 33 | SPK-LTCM-059 | Sleeve Kit |
| 34 | SPK-LTCM-060 | Rod, Limit Switch |
| 35 | SPK-LTCM-061 | Front Cover |
| 36 | SPK-LTCM-062 | Front Cover Assembly |
| 37 | SPK-LTCM-063 | Rear Cover |
| 38 | SPK-LTCM-064 | Cable Assembly, Up/Down Switch |
| 39 | SPK-LTCM-065 | Cable, Limit Switch |
| | E09-823 | Fuse, 1A, 250Vac, Time Delay |

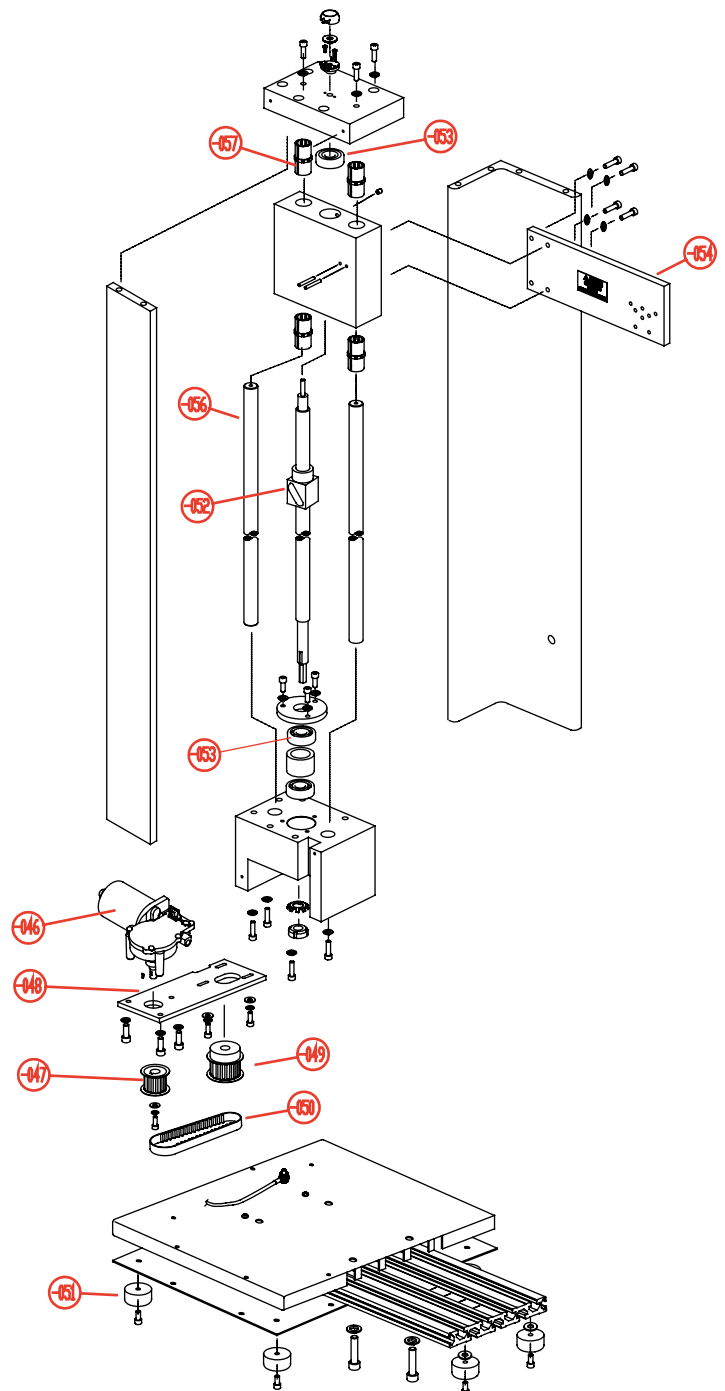

Parts highlighted in RED are common to both the LTCM-100 and LTCM-500

LTCM-500 Series Spare Parts

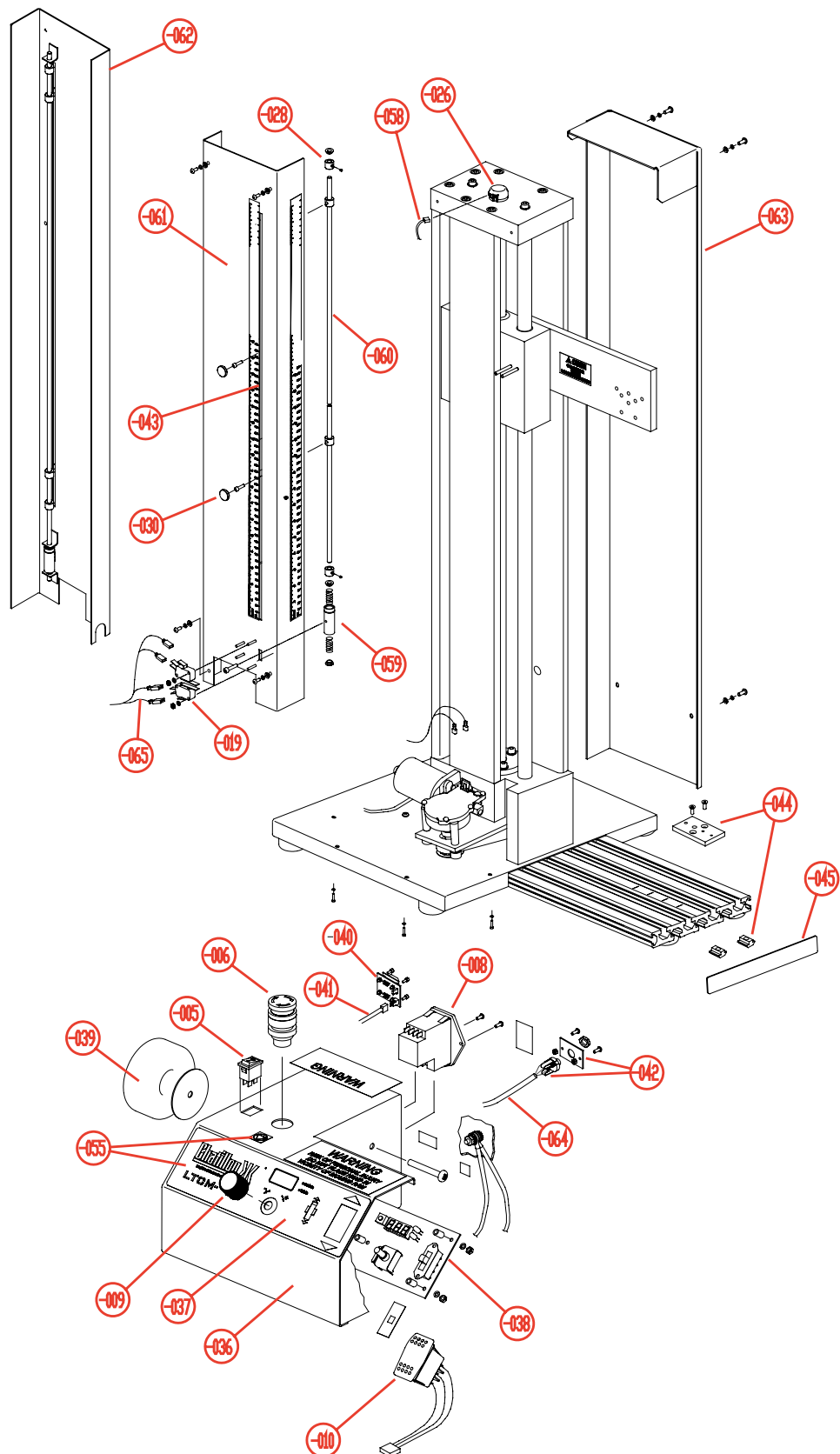

Troubleshooting

Symptom

LTCM Series will not power ON.

LTCM display reads “tAC”

LTCM display reads “OFF”

LTCM display reads “HOT”

LTCM display reads “LLL”

LTCM does NOT STOP at Load Limit with ENC0125 cable attached.

LTCM crosshead drives in only one direction. Display reads “LLL”.

LTCM Series moves DOWN but not UP.

LTCM Series moves UP but not DOWN.

Speed Display does not illuminate.

Troubleshooting Guide

Check that power is ON.
Check that Emergency Switch is disengaged (UP).
Check Power Source.
Check Fuses in Power Entry Module.
(See Checking Fuse)

Possible problem with Speed Encoder.
Crosshead may be blocked or erroneous encoder signal.

Motor voltage input may be too low.
Ensure Power Entry Module is set to correct source voltage.
(e.g. if set to 230Vac and 120Vac is supplied, LTCM is receiving only 50% of its expected voltage.)
(See Setting Power Requirements)

Motor drive circuit temperature is hot.
Ensure LTCM is not being overstressed due to overloading.
Let motor cool.
Contact Chatillon Representative if problem persists.

LTCM Series is at a load limit as sensed by either the Chatillon DF Series force gauge or SLC Series load sensor.

The Chatillon DF Series is likely manufactured BEFORE May 2006. The J3 jumper on the LTCM Series I/O PC board must be repositioned from 1-2 to 2-3. See “Using Digital Load Limits”.

The J3 jumper on the LTCM Series I/O PC board has been repositioned to 2-3, however the Chatillon DF Series force gauge is OFF or disconnected to the LTCM Series, or an incorrect cable is connecting the DF Series gauge and LTCM Series tester.

Possible problem with Upper Limit Switch.
Limit Switch is normally Closed.

Possible problem with Lower Limit Switch.
Limit Switch is normally Closed.

Check that power is ON.
Check that Emergency Switch is disengaged (UP).
Turn OFF power to the LTCM Series for 15 seconds, then turn power ON.

**International Symbols****WEEE Directive**

This equipment contains electrical and electronic circuits and should not be directly disposed of in a landfill site.

AMETEK[®]
TEST & CALIBRATION INSTRUMENTS**UK**

Tel +44 (0)1243 833 370
uk-far.general@ametek.co.uk

France

Tel +33 (0)1 30 68 89 40
general.lloyd-instruments@ametek.fr

Germany

Tel +49 (0)2159 9136 510
info.mct-de@ametek.de

Denmark

Tel +45 4816 8000
ametekdk@ametek.com

USA

Florida
Tel +1 (727) 538 6000
chatillon.fl-lar@ametek.com

California

Tel +1 (800) 444 1850
sales@crystalengineering.net

India

Tel +91 22 2836 4750
ametekdk@ametek.com

Singapore

Tel +65 6484 2388
ametekdk@ametek.com

China

Shanghai
Tel +86 21 5868 5111

Beijing

Tel +86 10 8526 2111

Guangzhou

Tel +86 20 8363 4768
lloyd@ametek.com.cn

www.chatillon.com